

ELIZABETHTOWN AREA WATER AUTHORITY



DESIGN, CONSTRUCTION, INSTALLATION, INSPECTION MANUAL

Board approved	7/3/2013	
Brd. Approved amendment	10/13/2014	Section 3.7
Brd. Approved amendment	7/1/2015	Section 2.0

TABLE OF CONTENTS

SECTION I – AUTHORITY, APPLICABILITY AND SCOPE..... 3

SECTION II – GENERAL DESIGN & PLAN REQUIREMENTS..... 5

SECTION III – SERVICE LATERAL CONNECTIONS 14

SECTION IV – MATERIALS 18

SECTION V – CONSTRUCTION, EXCAVATION, INSTALLATION 25

SECTION VI – INSPECTIONS & TESTING 36

APPENDIX 1 - WATER MAIN CONNECTION INSPECTION FORM..... 40

APPENDIX 2 – APPROXIMATE WATER USAGE GUIDELINE 43

SECTION I – AUTHORITY, APPLICABILITY AND SCOPE

This Manual is prepared under the authority of the Municipality Authorities Act, Act 22 of 2001, as amended, 53 Pa. C.S.A Sections 5601 et seq.; The Borough Code, Act 43 of 2012, as amended, 53 P.S. Sections 45101 et seq. Sections 47401 et seq.; The Second Class Twp Code, Act 60 of 1995, as amended, 53 P.S. Sections 65101, 67601 et seq.; Pennsylvania Safe Drinking Water Act, Act 43 of 1984, 35 P.S. Section 721.1 et seq. (25 Pa. Code Chapter 109); Pennsylvania Municipalities Planning Code, Act 247 of 1968, as amended, 53 P.S. Section 10101 et seq.

The purpose of this Manual is to provide the Elizabethtown Area Water Authority (EAWA) with:

- a guide, procedure, policies, specifications and minimum standards for the design, review, approval, construction, installation, inspection, and operation of water main connections, extensions, facilities and associated public works for the Authority, and work within its client municipal service area;
- a framework for public water system improvements;
- a rational and reasonable basis for decisions, which will promote quality, and timely and consistent service to the public and the regulated community.

All public water service connections, extensions, and related work to the EAWA water system shall comply with this Manual and requirements of the Pennsylvania Department of Environmental Protection. Nothing in this Manual shall affect regulatory legal requirements. EAWA reserves the discretion to deviate from this Manual if circumstances warrant.

Applicants shall file an application and provide the necessary agreements, documents, drawings, fees, and material, for any plan proposing a conversion, land development, or subdivision to create a new building / structure, lot, or unit of occupancy that has the effect of creating an additional Equivalent Dwelling Unit (EDU). *An EDU is defined as a residential or non-residential use, or unit of occupancy, that has an estimated water consumption of 170 gallons per day, as provided by Section 2.2, or the "Approximate Water Usage Guideline", or alternate calculation accepted by EAWA's Engineer.* Cost for partial EDUs shall be rounded-up to the next ½ level to cover peak - seasonal volume usage.

Abatement of pre-existing non-conformities: New development / subdivision projects shall conform to the specifications contained within this Manual. No approval shall be granted unless the proposed design and development conform to this current standard. An applicant / developer may request relief if good cause or a legitimate hardship can be sufficiently justified to the Board's satisfaction. All construction materials must be approved by EAWA prior to the start of construction. Submittal information shall include a list of materials and their source of supply as

well as manufacturer's descriptive catalog data, drawings, charts, tablets, and all documentation necessary to substantiate compliance with EAWA's specification requirements. List of materials and source thereof, together with work schedule, must be submitted and approved by EAWA before construction is started. Prior to start of construction, the developer/owner or his contractor shall submit a schedule of the work to be performed for review of EAWA's staff.

Consistent with the Second Class Township Code, as amended, 53 P.S. Sections 67603et seq., public water connection may not be required for those nonresidential uses, such as industries and farms which have their own supply of water for uses other than human consumption.

1.0 Definitions

AWWA - American Water Works Association.

Contractor - refers to any person constructing or installing a water main, or lateral, on behalf of an applicant, developer, or property owner. The requirements of this Manual shall also apply to the applicant, developer, or property owner, and EAWA shall have recourse to either party.

DICL- Ductile Iron, Cement Lined Pipe.

EAWA- Elizabethtown Area Water Authority.

OSHA- Occupational Safety and Health Act.

SECTION II – GENERAL DESIGN & PLAN REQUIREMENTS

2.0 Development / Subdivision Plan Submission, Review and Approval

For plans proposing the conversion, development, or subdivision, each individual unit of occupancy, including duplex, semi-detached, and townhouse units, potentially having separate ownership, shall have a separate service lateral connection. Individual structures or units, with a common owner and containing cooperative or rental apartments, commercial/office buildings, multi-unit industrial rentals, *not under separate / condominium ownership*, may have a common water lateral and meter.

As a means to ensure a convenient, effective, and equitable service arrangement for both customers and EAWA, it shall be a policy of the Authority to require that each individual unit of occupancy, which is not under common or condominium property ownership, to have a separate service lateral connection. EAWA shall require all customers to discontinue the use of a shared water service lateral, and provide a separate service lateral connection in any of the following circumstances:

- When water service must be shut-off, or terminated for lack of payment, or major repairs to water service facilities, excluding meter replacement;
- Any future installations or reinstallations of private service lines;
- When major repairs / replacements occur or are required to the private service lateral;
- When EAWA undertakes replacement of public water mains, and must reestablish private service tap-ins;
- When the municipality undertakes major public works to adjacent curbs, sidewalks, stormwater facilities.

For the above situations the affected property owner(s) shall be required to install a separate service line connection, at their own expense. However, at a minimum, a second curb stop box shall be installed, at EAWA's expense, from the shared lateral prior to entering the building / units in order to provide water turn-off for emergencies or termination of service. Assuming the repairs / replacements are not associated with an increase in usage or EDUs, the owners will be relieved from having to pay for the associated tapping fee (capacity and distribution). The actual design and layout of service connection and curb box shall be approved by EAWA to ensure a cost-effective installation and impact to both the owner and municipal facilities (curb, sidewalk, road, etc).

All applicants and/or developers are encourage to arrange a pre-design meeting with EAWA staff and consultants to assist in the identification of issues, or preferred development solutions.

For projects creating or requiring an additional EDU, the property owner shall submit

the following documents and material for review and approval of all applications and plans:

- a. Submit a complete application, outlining the details of the project, including estimated capacity, average and maximum daily and peak demand, total persons served, fire protection demand pressure and duration in hours, future build-out, along with fee;
- b. Submit escrow for the engineering review, and preparation of legal documents. The initial deposit amount shall be the lesser amount of \$1,000 per application, or \$50 per dwelling unit and/or per 1,000 ft² of non-residential or mixed-used space. The property owner will be responsible to pay for all associated development review costs;
- c. Three (3), Plan sets;
- d. Written verification of any municipal/zoning officer that approval has been received, or is pending;
- e. Plan notes specifying number and type of housing / units of occupancy, along with anticipated construction schedule;
- f. Construction elevations (U.S.G.S. datum);
- g. Planimetric mapping showing existing and proposed streets, property and lot lines, and building locations at a scale of 1 inch = 50 feet or less;
- h. Topographic mapping showing vertical relationship of new system to the existing. (NOTE: Planimetric and topographic may be combined or overlaid on each other); Profiles of all new water mains showing elevation and location of existing utilities; Profiles shall be 1 inch = 50 feet horizontal and 1 inch = 10 feet vertical or larger scale;
- i. Existing and proposed utilities including location and sizes of mains, valves, hydrants, and other facilities;
- j. Legend of symbols, scale, and date;
- k. A note that states: "All water main construction shall conform to the EAWA Design and Construction Manual, unless an exemption or waiver has been formally approved and cited on this Plan."
- l. A certificate that states: "The Elizabethtown Area Water Authority hereby certifies that: (a) this Plan has been approved for, or reserved capacity for: __ Equivalent Dwelling Units; (b) the Authority Engineer has approved the proposed design and construction; (c) a Water Extension / Development Agreement has been

executed; and (d) sufficient financial security has been provided to the Authority to fully cover the costs for capacity and installation of the planned improvements. Board Chairman _ Date _ / Alternate Authorized Official_ Date_";

- m. A note concerning the use of easements for lines providing fire suppression / sprinklers as per Section 3.1;
- n. A note concerning any water main easements, stating: "For lands within any water facility easement, EAWA shall have the right to trim, cut, or remove any tree, shrubbery, fence, structure or other obstruction that could reasonably interfere with the efficient, proper, and safe access and maintenance to the easement and/or the facilities that it contains. This shall include any of the noted objects or structures that exist at the time of this Plan / Agreement approval, and EAWA shall have no obligation to correct, replace, replant, restore such material, or be financially responsible for same;
- o. Copies of manufacturer specifications / shop drawings, certifying that pipe, fittings, valves, etc. provided and installed, comply with EAWA requirements.

In addition, lands within the easement shall not be paved-over, regraded, or otherwise have its access and maintenance hindered by significant changes to topography, creation of stormwater ponding, or hard surface paving. The Authority shall, however, be responsible to restore, as nearly as possible to the original condition, all land or premises located adjacent to its easement area, that may be disturbed, provided said restoration does not involve the replacement of trees, flowers, shrubbery, plants, structures, fences, or other obstructions, in violation of the above-noted easement."

After preliminary development plans, if required, have been reviewed and approved by EAWA, the applicant shall provide an estimate of the cost of completion of the water line extension reflecting the full cost to install the water facilities, including all related fire hydrants, accessories and appurtenances. At EAWA's discretion, the cost shall be determined by: (a) submission of a bona fide bid from the contractor, or (b) a detailed cost estimate prepared and certified by a Registered Professional Engineer.

After final plan review and approval, the applicant shall:

- Provide an irrevocable letter of credit from an authorized bank, performance bond, or approved equal security, guaranteeing the full installation (labor and materials) of all mains and associated public water improvements. The letter of credit must be in the form provided by EAWA and must be equal to 110% of the cost to install the water lines and appurtenances;

- If necessary, obtain a Water Quality Management Permit from the PA DEP. Although this permit will be issued in the name of EAWA, it is the responsibility of the applicant to apply for the Water Quality Management permit;
- Enter into a Development Agreement, Line Extension Agreement, or Easement – Right-of-Way Agreement, as may be required;
- Pay for the full Connection Permit(s), which shall cover the Customer – Meter, Capacity, and Distribution component fees, as applicable;
- Deposit additional funds, if necessary, in the development review escrow to cover the estimated cost of inspection and testing of the installation of the proposed water facilities;
- Provide a pre-construction schedule for the proposed construction, installation, inspection, and testing for all new facilities;
- A complete and accurate archival paper and digital copy of record drawings.

Upon satisfactory receipt of the above documents and monies, EAWA may sign the plans for recordation purposes. In no case shall EAWA provide building or occupancy approval unless the above documents and fees are provided.

Upon completion of the planned improvements, the applicant's Engineer shall submit certified As-built Plan(s) prior to the partial release of improvement escrow security (letter of credit, or other approved alternative). Acceptance and dedication of improvements shall not occur until As-built Plans are approved by EAWA. The private developer / Contractor will remain responsible for the facilities, including all maintenance and/or repairs until EAWA's acceptance. Any required repairs and/or maintenance EAWA does to the new facilities, in the interest of the general public prior to acceptance, will be charged to the private developer / contractor and/or reimbursement pursued via their bond.

EAWA reserves the right to create the required As-built drawing information and invoice the private developer / contractor, or obtain reimbursement via their escrow if these Plans are not provided within one-year of the completion of required improvements. For planned improvements involving a public dedication, EAWA will also hold escrow security for a warranty period of 18 months after dedication.

2.1 Financial Security for Plan - Public Improvements

No Plan shall be finally approved, or recorded, until the applicant or owner has provided financial security, in a form acceptable to EAWA and its Solicitor (e.g. irrevocable letter of credit), to cover the costs and guarantee the completion of all proposed public improvements, including curb, pavement, sidewalk, and other site restoration.

The amount of financial security to be posted for the completion of required improvements shall be equal to 110% of the costs of completion estimated as of 90 days following the date scheduled for completion by the developer. The cost estimate shall be based upon calculations certified to be accurate, fair, and reasonable by the developer's registered Engineer. Under recommendation by the Authority Engineer, EAWA may refuse to accept the cost estimate for good reasons.

Annually, EAWA may adjust the amount of the required financial security by comparing the actual cost of improvements, which have been completed and the estimated cost for the completion of the remaining improvements, as of the expiration of the 90th day after the original scheduled date for completion or a rescheduled completion date.

As the work of installing the required improvements proceeds, the party posting the financial security may request EAWA to release or authorize the release of, from time to time, portions of the financial security. Release requests shall be in writing, and addressed to EAWA. The Authority shall have 45 days after receiving a written request to ascertain from EAWA's Engineer, certified in writing, that the portion of the work has been completed in accordance with the approved plan.

When the developer has completed all of the necessary and appropriate improvements, the developer shall notify the Authority in writing of the completion of the required improvements and shall also send a copy thereof to EAWA's Engineer. EAWA shall, within 10 days after receipt of such notice, direct and authorize its Engineer to inspect all of the aforesaid improvements, file a written report detailing approval or rejection of the improvements, and reasons.

Upon authorization, EAWA shall promptly mail a copy of the report to the developer within 30 days after receipt by EAWA's Engineer. EAWA shall notify the developer, within 15 days of receipt of the Engineer's report, of its decision to accept or reject security release.

As part of this process, the improvements shall not be considered complete, and security shall not be released, until certified As-built Plans of all improvements have been reviewed and approved by EAWA and its Engineer. Upon EAWA acceptance of the required improvements and As-built Plans, the initial financial security shall be released, and EAWA shall consider the formal dedication of all or some of the required improvements and water mains.

EAWA shall also require the posting of financial security to guarantee the structural integrity of said improvements, as well as the functioning of said improvements in accordance with the design and specifications, for a period of 18 months from the date of acceptance of dedication. Said financial security shall be of the same type as otherwise required herein, and shall not exceed 15% of the estimated cost (labor and materials) for the installation of said public improvements.

2.2 Design Criteria & Water Demands

Applicants must demonstrate that the proposed activity, development, and use is designed to provide adequate supply of water during normal and peak demand usage (normal X 2.0) periods. The below criteria, and those listed on Appendix 2, shall be used to guide the design and calculation of EDUs, unless alternate standards / special exceptions are approved by EAWA, in writing, before any construction, installation, or plan approval is granted. In these cases, EAWA will require average and peak usage based on comparable and historically relevant flows, over a minimum 2-year period.

- a. Population (New Developments): 2.62 persons per unit
- b. Domestic Water Demand:
 - Average Daily Demand: 170 gallons / dwelling per day
 - Maximum Daily Demand: 250 gallons / dwelling per day
 - Maximum Hourly Demand: 4.0 times average daily demand
- c. Non-residential:
Appendix 2, or otherwise approved by EAWA's Engineer on case-by-case basis.

2.3 Water Pressures (High or Low)

New development will be evaluated on the basis of the ability of the system to supply a minimum of 40 psi at ground elevation and 20 psi during fire flow. Booster Pumps or stations shall be required, at the owner's or developer's expense, if pressure at any time during a normal day is at 40 psi or less. Pressure reducing valves shall be required, at owner's expense, if pressure is at 80 psi or greater.

Customers above an elevation of 570 feet in Elizabethtown and West Donegal Township and above 605 feet in Mt. Joy Township will require booster pumps. And, customers below 480 feet in Elizabethtown and West Donegal Township and 515 feet in Mount Joy Township will require pressure reducing valves.

2.4 Size and Location of Mains

Required minimum sizes are 8-inch diameter Class 52 DIP with cement lining for residential areas, and 12-inch diameter, Class 52 for main roads, feeder roads, higher density residential areas, and commercial – industrial areas.

Mains shall be located within public right-of-ways and roads, and looped. Dead-end mains shall be avoided. When unavoidable, fire hydrants shall be provided at the main dead-ends. Mains shall be located a minimum of 20 feet from the nearest structure, except as approved by EAWA. If it is necessary to locate a main on private property, the landowner shall provide a 20 foot wide, permanent easement,

centered on the main, in the name of EAWA. An additional, 20 foot wide temporary construction easement shall be provided.

Mains shall extend to the perimeter limits of the parent tract or subject property line to ensure convenient future connection - extension of water service to adjacent lands. In cases where this option is demonstrated to be uneconomical a partial extension shall be provided along with an easement in favor of EAWA to facilitate future connection.

2.5 Easements and Utility Separations for Mains

Water mains near sewers and stormwater facilities shall conform to the PA DEP Water Supply Manual. Water mains shall be laid above sewer and stormwater lines, and at least 10 feet, horizontally, from these existing or proposed lines. If a water main needs to cross under a sewer or stormwater facility, a full-length of water main pipe shall be centered under the pipe, with a minimum vertical separation of 18 inches, and the water main shall be encased in concrete for a minimum of 10 feet on each side of the crossing. Concrete shall extend a minimum of 12 inches from outside perimeter of pipe. No water pipe shall pass through, or come into contact with, any part of a sewer manhole.

2.6 Cross Connections / Contamination

As per Chapter 109 - Safe Drinking Water, Title 25 of PA Code, any water source or supply, other than from the EAWA's system, shall not be connected to customer piping served from the EAWA system. All potential cross-connections shall be eliminated and EAWA shall require customers to install backflow preventers.

2.7 Severing of Existing Domestic Wells

Customers must sever building connections to wells. Customers may maintain separate well source for irrigation provided that no piping from the irrigation source enters customer's building.

2.8 Minimum and Maximum Cover Over Pipes

The minimum depth of backfill over pipes shall be 48 inches. When this depth cannot be provided, insulated construction, approved by EAWA, shall be used. Maximum cover shall be 5 feet, unless otherwise approved by EAWA.

2.9 Location of Valves

A minimum of three valves shall be used at main intersections, and a minimum of two valves at "T" intersections. EAWA reserves the right to require more valves as determined by the Authority Engineer. Valves shall be placed at least every 300 feet on arterial mains and minor distributors, or at other selected points throughout the distribution system as determined by EAWA. All water mains shall extend at least

60 feet beyond each valve with restraining gaskets, located on a dead-end main, unless otherwise approved by EAWA.

2.10 Dead Ends

All water mains shall be restrained for a minimum of 60 feet upstream of each dead end with restraining gaskets. Dead ends which will be extended in the future shall normally consist of tee with hydrant on branch, and gate valve and plug at the dead end. Tee, hydrant connection and gate valve shall be provided with joint restraint (Mega-lug or equal.) Dead ends which will not be extended in the future should be provided with a fire hydrant.

2.11 Air Release and Vacuum Valves

Air release valves, where required, shall meet AWWA C512 standards, as manufactured by Crispin "C" Series. Valves shall be sized as per manufacturer's recommendations based on main size, main capacity, and pressure.

2.12 Blow-offs

Blow-offs shall be discouraged. Instead, fire hydrants shall be installed on the end of lines to aid in main flushing.

2.13 Pipe Slopes

Abrupt pipe slopes (such as where the water main crosses under other utilities) should be avoided and pipe depth differentials should be made gradually rather than with elbows. Water mains should be located above storm and sanitary sewers where possible.

2.14 Fire Hydrants

Fire hydrants shall be required and installed, at the Developer's expense, for all land developments / subdivisions, and community public works projects, consistent with AWWA C600, and according to the standard design details. Fire hydrant branches shall not be less than 6 inches in diameter and no longer than necessary. The maximum permissible length is 50 feet unless a longer length is approved by EAWA. The Authority reserves the right to increase the size of the hydrant branch proposed when such a change is warranted as determined by the Authority's Engineer.

- a. Hydrants shall be located on public right-of-ways, and at all road intersections, unless the Board accepts recorded public easement agreements, secured and paid for by the developer and/or owner. Hydrants shall be required along one side of any right-of-way;

- b. In Residential or mixed-use areas, hydrants shall have a maximum spacing of 500 feet. For medium to high density areas, with a density of 8, or more, dwelling / occupancy units per acre, a maximum spacing of 300 feet shall be required;
- c. For predominantly non-residential areas (more than 50% commercial, industrial, institutional, office land area), a maximum spacing of 500 feet shall be required. For developments that are designed for "big box" retail, campus type, or industrial multiple configuration, all buildings or structures shall be no further than 300 feet from a hydrant;
- d. Provide hydrants at all high and low points on the distribution main;
- e. On curbed roads, install hydrants immediately behind the edge of the curb; On un-curbed roads, hydrants shall be 4 to 6 feet from the edge of paving or shoulder;
- f. A valve shall be installed on each hydrant branch pipe between the main and the hydrant;
- g. All hydrants shall stand plumb with the pumper nozzle facing the curb, and six (6) inches behind it, and the hose nozzles parallel to the curb. All hydrants shall be set on an 8" x 8"x 16" solid block;
- h. Hydrants shall be color-coded with reflective markers indicating actual flow rate;
- i. No fence, structure, lawn ornaments, landscaping, trees or shrubs, shall be located within 5 feet of a hydrant;
- j. In private parking / loading areas, hydrants shall be protected by anchored metal or concrete bollards; Along roads, fire routes, or other areas, EAWA may require that signage or other demarcation be provided prohibiting parking;
- k. Hydrants shall be compression type with a 5-1/4 inch main valve, and a 6-inch mechanical joint inlet. Hydrant shall have two, 2-1/2 inch hose nozzles, and one, 4-1/2 inch pumper nozzle, complete with nozzle cap chains. Hydrant shall be traffic type with breakable safety flange and stem coupling and shall open counter clockwise. A hexagon operating nut shall be provided with National Standard threads on the hose and streamer nozzles. Hydrants shall conform to AWWA C502 and shall be leak proof at the design pressure. Hydrants shall be Mueller Centurion, Model A423 (no substitution).

SECTION III – SERVICE LATERAL CONNECTIONS

3.0 Customer Connection Service Line & Replacement

New connections, or applicants requesting additional EDUs, may secure and pay for these by:

- i. full payment of Connection Permit;
- ii. partial initial payment of Capacity, and Distribution component (tapping) fees, in conjunction with approval of Development Agreement by EAWA;
- iii. partial initial payment of Capacity component (reservation) fee, in conjunction with approval of Development Agreement by EAWA;.

The Connection Permit expires within one year from the date of issue, if connection is not made. Permit is not transferable.

Partial payment of Capacity and/or Distribution component is subject to conditions and restrictions that may be made in each Agreement, but in no case shall this commitment / reservation extend beyond 5 years, unless the EAWA Board grants an extension. Under these arrangements, the applicant paying for Capacity and/or Distribution allocation shall represent and have responsibility for the entire development or property. The applicant shall also file a schedule of anticipated phasing, including start of construction, rate of connections, and date of completion.

The sizing of customer service lines shall be subject to EAWA approval and shall be based on the length of line and the water demand. Residential service lines shall normally be $\frac{3}{4}$ inches in size unless a larger diameter is needed because of distance. The service line shall typically consist of:

- a. Corporation stop;
- b. Copper (refer to section 4.7,4.8) or HDPE tubing;
- c. Detection Tape and Tracer Wire;
- d. Casing pipe for HDPE tubing, Schedule 40 PVC;
- e. Fittings for Copper or HDPE tubing;
- f. Curb Stops and Boxes;
- g. PVC Pipe when needed: 3 inches and smaller, for through basement wall, shall be Schedule 40 PVC conforming to ASTM Designation A 120;
- h. Customer Meter (supplied by EAWA).

Trenchless replacement of existing service lines shall be limited to using new copper service lines. Replacement of existing service lines with non-copper materials such as plastic or HDPE *is prohibited for trenchless applications.*

3.1 Sprinklers

For land development and/or subdivision plans proposing apartments, multi-family and townhouse units, two separate lines shall be provided - one for domestic and one for fire suppression. For townhouse developments, refer to design (see detail prepared by CET Engineering Services, dated 12/22/11).

3.2 Protective Sleeve

At the entry of the service line into the building a protective sleeve shall be provided through the wall of the building. The sleeve shall be PVC Schedule 40 (or heavier) pipe and shall span across the excavated area outside the wall and at least two feet of the end of the sleeve shall rest on virgin soil. The copper or HDPE tubing shall be passed through the sleeve and the annular space on the house side of the sleeve sealed with non-corrosive silicon based sealant.

3.3 HDPE Water Service Tubing

- a. HDPE usage shall be limited to water service lines from ¾ inch to 2" diameter;
- b. Only copper tubing shall be used for the pipe between the corporation stop and curb stop. HDPE or copper tubing can be used for service lines;
- c. Pipe shall be HDPE CTS Pipe PE3608/3408 or PE3408 /4710 with a pressure rating of 200 psi. Pipe shall meet requirements listed under NSF Standard 61;
- d. Polyethylene pipe shall be manufactured in accordance with AWWA C901;
- e. The following information is to be printed on the pipe: Identification of the manufacturer, The CTS designation and nominal diameter, identification of PE 3608/3408 or PE3408/4710 high density resin, AWWA and NSF standards;
- f. Pipe shall be suitable for connections with CTS compression fittings to curb box and meter;
- g. Pipe shall be installed from one continuous roll. No connections (HDPE to HDPE) other than to meter and curb stop shall be permissible;
- h. Installation of tracer wire and detection tape is required for all HDPE installations. Tracer wire shall extend from curb stop to customer wall penetration;
- i. Curb stops for HDPE piping shall meet requirements of Section 4.9. HDPE connection to curb stop shall be provided with Mueller 110 liner;
- j. HDPE service lines shall be provided with a Schedule 40 PVC casing with solvent weld joints for service pipe under driveways, parking lots, roads and other areas with vehicular travel. Casing can be provided at the option of the Contractor

but is not required for lawns. For ¾" and 1" service lines the casing shall be 2" size. For 2 inch service lines, the casing shall be 4 inches in size.

3.4 Installation of HDPE Service Lateral

Place the pipe so that it is relaxed and "snakes" loosely in the trench. Do not bend the pipe more than the minimum bend radius for the Dimension Ratio rating. The D.R. rating is the outside diameter / minimum wall thickness, which range from 32.5 (50 PSI working pressure) to DR7 (265 PSI working pressure). Placing pipe that has been in direct sunlight in a cooler trench will result in thermal contraction of the pipe's length. This contraction can generate force which could result in pull-out at mechanical couplings or other buried structures. Allow pipe to cool before making connections to an anchored joint, flange, or a fitting that requires protection against excessive pull-out forces. Covering the pipe with embedment will facilitate cooling. HDPE tubing shall be installed in PVC casing that starts at curb stop and connects to protective sleeve at building wall.

3.5 Tracer Wire

Install tracer wire along the entire length of buried HDPE service pipe, which shall be 10 AWG solid HDPE30 MIL copper conductor, 30 mil thick, high-density, insulated and rated for 30 volts. Tracer wire to be placed on top of pipe with waterproof silicone tape at 5 feet intervals. Leads for tracer wire shall be terminated at the curb stop valve box. Run wire up around the exterior of the valve box. Silicone tape shall be used to attach wire to curb box. Tracer wire shall be continuous and without splices. Tracer wire ends shall be enclosed with waterproof connectors. Continuity tests shall be conducted by the contractor. Testing shall be done in the presence of and to the satisfaction of the engineer. Tracing wire installations that fail the continuity testing shall be corrected and retested to EAWA's satisfaction.

3.6 Pressure Tests

Pressure tests for copper and HDPE service pipe tubing shall be required to ensure that new lateral can withstand 150 PSI for a 1 hour period without a pressure loss.

3.7 Backfilling of Lateral

Service lateral bedding for copper piping shall be non-limestone select granular material, or masonry sand, conforming to PennDOT Publication 408, Section 703.1, 703.2 or 703.3 respectively. Bedding shall be placed 6 inches below and 6 inches above the water line.

For HDPE pipe, there shall be at least 6 inches of sand below the pipe, and 12 inches of sand over the pipe, before compaction of the final backfill material. To avoid breakage of plastic pipe, contractor shall use hand shovel compaction in lifts not exceeding 8 inches.

3.8 Abandoning Water Service Line

For abandoning an existing service line to a building, the service shall be disconnected at the water main, the corporation removed and an approved; stainless steel sleeve be placed on the main. The old service line will then be removed from the water main to, and including, the curb stop.

SECTION IV – MATERIALS

4.0 General

Interior of all materials, including coating shall meet NSF61.

4.1 Ductile Iron Pipe

All water mains shall be ductile iron, cement lined pipe, which shall conform to ANSI A21.51 (AWWA C151) Class 52, and AWWA C104. DICL pipe, installed in corrosive soils, must be wrapped with an approved plastic covering. Joints shall be push-on (conforming to ANSI A21.11). Supply joints with all required accessories. The Contractor shall submit to EAWA, in triplicate, a certificate from the manufacturer that the pipe furnished complies with all applicable requirements of ANSI A21.51. Minimum thickness of DICL shall conform to AWWA C150.

4.2 Fittings & Restraints

Ductile iron fittings shall be provided for all DICL pipes. Fittings shall have a minimum pressure rating of 250 psi, and shall conform to AWWA C 110. Fittings shall be furnished with mechanical joint ends conforming to ANSI A21.11, complete with either gray iron or ductile iron glands, bolts and nuts, and gaskets - Mega-lug joint, or equivalent. At any bend or fitting, joints shall be restrained by 5 joints on either side. Restraint shall be Field Lok 250 gasket on pipes with Mega-lug restraint, or equivalent, on MJ fittings.

Flanged fittings, for exposure piping or when specified on the Drawings, shall conform to ANSI A21.10 or ANSI 816.1. All flanges shall be faced and drilled in accordance with ANSI 816.1. Machine bolts and nuts for flanged fittings shall be stainless steel, conforming to ASTM Designation A307, Grade 8. Dimensions of bolts and nuts shall conform to ANSI 818.2. Threads of bolts and nuts shall conform to ANSI 81.1, Coarse-Thread Series, Class 2A fit on bolts, and Class 2B fit on nuts. Dimensions of gaskets shall conform to ANSI 816.21.

All fittings shall be cement-mortar and bituminous coated outside, conforming to AWWA C 104. The Contractor shall submit to EAWA, in triplicate, a certification from the manufacturer that all fittings comply with the ANSI Standards noted above.

4.3 Cement-Mortar Lining

Cement-mortar lining shall conform to ANSI A21A (AWWA C104), except that the lining thickness shall not be less than 1/8-inch for 4-inch through 12-inch main sizes and 3/16-inch for 14 inch through 24 inch main sizes.

4.4 Valves

Valves 14 inch and larger shall be butterfly valves as long as valve design pressures are not exceeded. Valves 4 to 12 inches shall be resilient seated gate valves (AWWA C509).

4.4.1 Butterfly Valves

Valves shall be the short body type with mechanical joint or push-on joint ends, constructed of ductile iron conforming to ASTM A 126, Class B. All valves bodies shall have two hubs for shaft bearing housings, cast integrally with the body. Body shell thicknesses shall conform to Table 3 of AWWA C504. Valves shall be painted in accordance with AWWA C504, Section 4.2.

Valve shafts shall be one piece or two-piece units securely attached to the valve disc. Valve shafts shall have a minimum diameter as specified in Table 4 of AWWA C504, and shall be 18-8 stainless steel, Type 304. Shaft seals shall conform to AWWA C504, Section 3.7. Bearings shall be nylon, reinforced Teflon, or graphite bronze.

Valve seats shall provide leak-proof shutoff with design pressure on one side and zero pressure on the other side. Valve seats shall be the 90 degree type, and shall be bonded and/or mechanically secured to the valve body or disc. Valve discs shall be alloy cast iron conforming to ASTM A436, Type 1 or 2, or ASTM A439, Type 02, with a maximum lead content of 0.003%. Valve operators shall be the worm gear or traveling nut type, fully enclosed, and fitted with a standard 2 inch square operating nut. Operators shall produce the required output torque with a maximum input torque of 150 foot pounds on the operating nuts. All valves shall open to the left. Valves shall be Mueller, American-Darling or DeZurik. The Contractor shall furnish manufacturer's certified shop drawings, in triplicate, to the EAWA for approval. The manufacturer shall also certify that the valves comply with AWWA C509.

4.4.2 Resilient seated gate valves

Gate valves shall be 4 to 12 inch and shall be resilient seated, meeting or exceeding AWWA C509. Gate valves shall have mechanical, or push-on joint ends and be equipped with 2 inch non rising operating nuts and be suitable for buried applications. Valves shall open when turned to the left. Valve shall have fusion bond epoxy coating on the inside and outside of the valve. The valve shall be made by American Flow Control.

4.5 Tapping Sleeves & Valves

Contractor shall verify the type of existing pipe and the outside diameter of pipe on which the tapping sleeve is to be installed. Tapping sleeves and bolts shall be stainless steel. The sleeves shall be made in two halves which can be assembled

and bolted around the main. Gaskets shall extend the entire length of the sleeve to form a watertight joint when the side bolts are properly tightened. Design for 200 psi working pressure. The tapping valves shall have flanged inlets with mechanical joint outlets. All valves shall be vertical ductile iron body, bronze mounted, inside screw valves with 2-inch non-rising operating nuts. Valves shall open to the left, and shall be fitted with O-ring seals. Tapping valves shall conform to the applicable section of AWWA Standard C500.

4.6 Valve Boxes

Underground valves shall have extension-type, roadway-type valve boxes. Valve boxes shall be cast iron material with a strong magnetic attraction, and shall have threaded construction. Valve boxes shall have 5-1/4 inch shafts, shall have covers marked "WATER", and shall be coated inside and out with a tar or asphalt compound, made by Tyler, or Bingham Taylor.

4.7 Copper Tube

Copper tube shall conform to the requirements of ASTM B-88, with Type K underground and Type L in exposed locations. No splices permitted in lengths less than 100 feet.

4.8 Fittings for Copper Tubing

Fittings for underground copper tubing shall be compression type conforming to ANSI B16.26, Cast Copper Alloy Fittings for Compression Copper Tubes. Fittings for exposed copper tube shall be 125-pound bronze screwed fittings, conforming to ANSI B16.15, or 250-pound fittings, conforming to ANSI B16.17. Fittings shall be three-part straight couplings and shall be Mueller Company H-15400 or Ford C 44-33Q (no substitutes). Straight couplings connecting copper to male iron pipe thread shall be Mueller Company H-15450 (no substitutes). Straight couplings connecting copper to female iron pipe thread shall be Mueller Company H-15425 (no substitutes).

4.9 Corporation, Curb stops and Boxes

Corporation stops shall be installed at the low and high points of the water main to facilitate hydrostatic and pressure tests. They should be tapped at 90 degree (horizontal) angle to the main. Service line shall be installed as a continuous length of pipe and shall have a minimum cover of 4 feet from the main into the building being serviced. Curb stops shall be vertical, with the top of the curb box at finished grade. Where grading may be still in progress, the curb box shall be marked with a 2 ft. high stake, painted blue.

Corporation stop shall be designed to AWWA C800. Corporation stops shall be Mueller 110 or Ford F1000-3Q Compression Connection Outlet (no substitutes allowed).

Curb stop and box, designed to AWWA C800, should be all bronze construction, inverted key stop. Curb stops shall be Mueller 110 or Ford B44-333Q Compression Connection Outlet (no substitutes allowed).

Box must be extension type arch pattern base of two-piece cast-iron construction coated inside and out with tar base enamel and topped with cast iron lid secured with bronze bolt. Curb boxes shall be Opelika B & T, 2 ½ new style flush fit covers with foot piece. All covers shall be marked "WATER".

4.10 Steel Casing Pipe and Casing Spacers

- a. Smooth steel wall casing pipe conforming to ASTM A-252 Grade 2 or ASTM A-139 Grade B, minimum plate thickness 0.375-inches. Casing shall be uncoated. Minimum yield strength of 35,000 PSI.
- b. Casing spacer bonds shall be 304 stainless steel, 14 gauge;
- c. Casing shall be filled with sand and ends of casing pipe sealed water tight;
- d. Casing spacers shall be manufactured by PSI, Inc. of Houston, Texas or equal.

4.11 Mechanical Couplings

Ductile iron mechanical couplings of the gasket, sleeve type shall be furnished and installed where shown on the Drawings, or where required. The coupling shall be of the proper diameter to make a tight joint. The coupling shall not have stops. All couplings shall be for 150 PSI working pressure. Each coupling shall consist of one center sleeve of a thickness and length suitable for the proposed application and test pressures; two DI end rings; two rubber compounded wedge section gaskets and sufficient stainless steel bolts to properly compress the gaskets. Couplings to be buried shall be coated on the inside and outside with two coats of asphaltic varnish in accordance with federal specification TT-V-51c, manufactured by Ford FC] or equivalent.

4.12 Flanged Coupling Adapters

Flanged coupling adapters shall have a cast iron body and a malleable or ductile iron follower flange. The flange bolt circle, bolt size, and spacing shall conform to ANSI Standard B16.1, Class 125. Flanged coupling adapters shall have two anchor studs for up to 8-inch pipe size, and four anchor studs for 10 and 12-inch pipe sizes. Flange coupling adapters shall be Smith-Blair, Romac or EBAA.

4.13 Pressure Regulating Valves

Pressure reducing valves on customer service piping will be installed, owned and maintained by owner. Pressure reducing valves shall be designed to maintain customer pressures less than 80 PSI.

4.14 Pre-Cast Vaults

Pre-cast vaults shall be provided where customer service requires use of large diameter buried meter and or/valves. Vault walls are to be 8 inch thick reinforced concrete. Top slab shall be 8" thick reinforced concrete. Vault floor shall be 6" thick concrete. Concrete shall conform to Penn DOT Specifications, Form 408, Section 704, Cement Concrete and Ready-mixed Cement Concrete. All reinforcing steel shall be a minimum #4 steel rod, free from dirt, oil, grease or avoidable rust. It shall be cleaned and free of loose rust. Waterproofing shall be Thoroseol. U.S. Chemical Tarmastic # 102, Koppers Bitumastic Super Service Black, Damchex, Amercoat #78, or approved equal. The annular void between pipes and chamber walls shall be sealed with modular mechanical seals with rubber links, pressure plates and related hardware equal to PSI- Thunderline / Link-Seal, or equivalent.

The vault floor drain casting shall have a 4" outlet and a raised or beehive dome grate similar to the Wade # 1634, East Jordan #61 04-N, or approved equal. Provide French drain for vault floor drain, which shall consist of 1 cubic yard of buried crushed stone, AASHTO #8, connected to 3" floor Sch 80 PVC drain pipe. Where there is insufficient elevation drop around the vault to accommodate a French drain, a sump can be cast into the vault floor in lieu using a floor drain subject to approval by the Authority. Sump dimensions shall be 12"x12"x8". Vault steps shall be forged 6061-T6 aluminum alloy or Fiberglass reinforced plastic cast into the precast vault, and shall be aligned vertically and spaced a maximum 12 inch apart on equal centers, and shall satisfy OSHA requirements.

Vault lids shall be composed of 0.25-inch (1/4") thick aluminum rated at 150 pounds per square foot (rated for an H-20 loading in traffic bearing situations). Lids shall be affixed with stainless steel hinges and hardware and shall be a minimum of 3' x 3' centered over the meter and/or backflow device. A retractable handle constructed of stainless steel shall be furnished with each lid such that when the lid is closed, there shall be no protrusions above the lid level.

The channel frame shall be 1/4-inch minimum aluminum with anchor flange around the perimeter with a drain into the meter pit. Factory finish shall be mill finish. Each lid shall be furnished with a stainless steel snap lock with gasketed, threaded cover plug and removable key wrench, and a stainless steel hold-open arm with release handle for securing the lid in a 90 degree open position. Also, compression-spring operators enclosed in telescopic tubes shall be provided for smooth, easy and controlled door operation throughout the entire arc of opening and closing. Aluminum meter pit lids shall be Bilco model #J-4AL, or approved equal.

4.15 Meters

Meters will be supplied by EAWA as part of the Connection Permit application and fee. Ball valves shall be installed on both sides of the meter. No meter by-pass lines will be accepted except in installations at emergency institutions (hospitals, etc.). Water meter shall be installed by developer horizontally and supported as necessary. A backflow preventer (Watts Model #7) shall be installed on the customer side of the meter.

Water shutoff valves shall be installed on both sides of the water meter with one of those valves to be installed on the house side of the backflow preventer. Thermal expansion device shall be located on the supply line of hot water heater. Internal wiring shall be placed within a plastic conduit from the meter location inside the building to the radio reading location on the outside of the building. The plastic conduit shall be at least 1;2 inch in diameter. Radio pad shall be located on front of building when at all possible or on either side, located within 3' of front of building with no wire showing. Keep obstructions away from pad, providing a minimum of 3 feet access in front.

4.16 Meter Pits

Meter pits shall be used where service pipe length is greater than 150 feet, in the case of multi-EDUs, or on a case by case basis as determined by the Engineer. Meter pits shall be plastic pit setters designed for cold weather service to prevent pipe freezing with a service pipe depth of 4 feet. Minimum pit depth shall be 4 feet and minimum diameter shall be 18 inches. Service lines shall be kept at a minimum of 2 inches from the pit wall.

Pit shall be complete with copper tube risers, angle ball valve, dual check valve compatible with dimensions of meter provided by EAWA. Pit setter shall have provisions for mounting radio read transmitter inside the top of the units. Pit setters shall be per Ford catalog section FA. Install Radio Read inside top of meter pit.

4.17 Backflow Preventer

Backflow prevention devices shall be provided in accordance with state and federal requirements. As a minimum, a backflow prevention device (Watts Series 7) shall be installed on all water service. It shall be installed directly after the meter. Provide a thermal expansion device, on the supply side of the hot water heater.

4.18 Reduced Pressure Backflow Preventers

This device shall be used at connections where toxic chemicals, sewage, or other substances determined by the EAWA or state and federal guidelines to be hazardous and which could be in contact water on customer's premises. It shall

conform to AWWA C511 shall be minimum 150 PSI design pressure, and shall be equipped with suitable test cocks. Backflow preventers shall be BEECO Model 12 or 6-C, CLA-VAL Co. Clayton Model RP-2 or RP-1, Watts Regulator Company Series 909, or equivalent.

4.19 Double Check Valve Assemblies

This device shall be used at connections where nuisance materials, such as foods and beverages, or other materials that do not constitute a health hazard, might enter the distribution system. It shall conform to AWWA C510, shall withstand a 150 PSI design pressure, and shall be equipped with suitable test cocks. The device consists of an assembly of independently acting check valves located between two tightly-closing shut-off valves but without a pressure differential relief valve. All double check valve assemblies shall be BEECO Model VC, Hershey No.1, CLA-VAL Co. Clayton D, or equivalent.

4.20 Detection Tape

An approved water line detection tape shall be placed no less than 18 inches above and centered on the water main and service connection.

SECTION V – CONSTRUCTION, EXCAVATION, INSTALLATION

5.0 Working Conditions

Except for emergencies, no work shall occur after 4 P.M., during regular Monday-Friday, or Saturday, Sunday, or Holidays, unless expressly permitted by EAWA in writing, in order to allow for regular EAWA inspections. No work shall be done when, in the opinion of the Authority, the weather is unsuitable. Contractor shall protect the work site from weather related damages.

5.1 Permits and Licenses

The Applicant, on behalf of EAWA, shall obtain the necessary permit from Penn DOT for the occupancy of State Highways or from the municipality for any necessary approval to construct facilities in municipal right-of-way.

5.2 Liability, Quality Assurance, Special Requirements

The Contractor shall be responsible for any and all damage, loss, or injury to persons, property, and EAWA facilities, which may arise, or be incurred, in or during the conduct or progress of the work.

- a. Developer, Contractor, or property owner shall schedule a pre-construction meeting with EAWA staff, a minimum of 2 weeks prior to any construction or installation of mains, hydrants, or other additions onto system. Contractor shall provide Emergency Contact List, tentative dates for mobilization, excavation, installation, inspection, testing, and completion;
- b. Construction of water mains and appurtenances shall conform to the requirements of OSHA;
- c. All equipment used on roadways shall be equipped with rubber tires or treads. If other than rubber tires or treads are used, the pavement shall be protected by heavy rubber belting;
- d. Contractor shall maintain existing water mains in service. If an existing water main is damaged or broken, the Contractor shall expeditiously restore service at his or her expense;
- e. Contractor shall inform the local Police and Fire Departments Schools and Public Transportation of work schedule and of possible street obstructions, and also provide a list of Emergency Contacts;
- f. Contractor shall repair or replace all defective equipment or piping;

- g. Contractor shall undertake pressure and biological testing for new facilities, and provide results to EAWA's satisfaction;
- h. Contractor shall keep excavations free of water, and shall comply with Lancaster County Soil Conservation District regulations;
- i. Contractor shall be responsible for removal, realignment, or change in the position of any pipe, conduit, pole, or other structure, which may obstruct his construction. Trees that are cut down shall have their stumps removed, and all resulting debris shall be removed and disposed of by the Contractor, and the site, pavement, driveways, and right -of-way shall be restored to the original condition at his expense;
- j. Contractor shall maintain and protect from direct or indirect injury, all poles, pipes, conduits, tracks, roadways, curbs, walks, walls, buildings, and other structures or property in the vicinity of work;
- k. Contractor shall be responsible for all clearing and grubbing of vegetation, consistent with State, County Conservation District, and local laws;
- l. Any pipes, hydrants, valves, or other equipment that is dropped during handling is subject to rejection regardless of its apparent condition;
- m. Contractor and/or Developer shall obtain and maintain in force liability insurance at all times during the installation and construction work. The minimum limits and coverage shall be approved by EAWA and any policy or policies of insurance shall name the Authority, its officers, officials, agents, servants, employees and engineer, as additional insureds. Developer shall indemnify and hold the Authority and its officers, officials, agents, servants, employees and engineer harmless from any and all liability, claims or expenses arising from damages relating to the construction of the water mains;
- n. Contractor shall ensure that upon completion of work, public roads have been restored to a mud-free, or otherwise permanently passable condition.

5.3 Exploratory Test Pits

Test pits shall be dug, at the applicant's or developer's expense, in advance of trench excavation when necessary to determine the location and depth of existing utilities, rock, water levels, or other conditions that might affect construction.

5.4 Work Area Traffic Control & Maintenance

Contractor shall take all necessary measures to keep roads open and safe for traffic. Contractor shall obtain written approval/permits to close a street. Traffic in work

areas shall be controlled to protect the public and workers, while minimizing the inconvenience to the public. Traffic control devices shall conform to the PA Department of Transportation Regulations Governing the Design, Location and Operation of all Traffic Designs, Signals and Markings on or along Highways within the Commonwealth of Pennsylvania; the current revision of Bulletin # 15, 43 and 730; and the Penn DOT Publication 112, and 203.

When appropriate, work shall be performed during times other than peak traffic periods. Access to residential and business establishments shall be maintained, except when work is actually being performed in the area. Trenches across driveways, side streets, alleys, and entrances shall be maintained after backfilling. The Contractor shall construct, furnish, and maintain all barricades, bridges, fencing, lighting, personnel to implement safety work traffic zone. All stored materials and equipment, which may present possible obstructions to traffic, shall be protected. Contractor shall not obstruct fire hydrants.

5.5 Compliance with PA One Call for Utility Markings

Contractor shall comply with PA Underground Utility Line Protection Law (Act 287 of 1974, as amended by Act 121 of 2008), intended to protect underground utilities from damage during excavation. Generally, the Acts require the Contractor to ascertain the location and type of utility lines at the work site and to request detailed information from each user (utility owner or operator) not less than three working days before beginning work. The Contractor must provide operators with the information and must inform any user of any damage made or discovered during construction. Utility notification number required for design and construction.

5.6 Delivery, storage And Handling

- a. Deliver, store and handle the piping, valves and specials in accordance with the manufacturer's recommendations, and as supplemented herein;
- b. Pipe and related materials shall be loaded and unloaded by lifting with hoists or skidding so as to avoid shock or damage. Under no circumstances shall such material be dropped or skidded against piping already on the ground;
- c. Pipe and related materials shall at all times be handled with care to avoid damage. The interior shall be kept free from dirt and foreign matter. All pipe, valves and appurtenances shall be carefully lowered or raised into place, with suitable equipment in a manner that will prevent damage to the material. Under no circumstances shall pipe or accessories be dropped or dumped;
- d. Pipe, pipe linings, fittings, valves, and all related materials shall be thoroughly inspected for defects prior to their being installed. Any defective, damaged, or unsound material, as determined by EAWA, shall be repaired or replaced as directed at no additional cost;

- e. All lumps, blisters and excess coating shall be removed from the ends of each pipe. The joints shall be wire brushed and wiped clean, and dry and free from oil and grease before the pipe is installed.

5.7 Excavation – General

Excavation and backfill work shall conform to the AWWA Standard for Installation of Cast Iron Water Mains, C600 plus the changes and additions specified herein. The Contractor shall conform to the regulations of all governmental agencies having jurisdiction over the work.

Standard details for trench excavations, are attached to these Specifications and are made a part thereof. These details cover earth trenches, rock trenches, trenches in unsuitable soil, trenches in roadway shoulders, and trenches in paved areas. The term "subgrade", as used herein, shall have the following meanings:

- a. The planned bed of a trench prepared to receive bedding material;
- b. The area upon which the lower surface of roadway paving rests;
- c. The area upon which the planned bottoms of manholes rest.

5.8 Rock Excavation

Unless otherwise approved by the Authority, rock shall be removed from the trench at least 25 feet in advance of pipe laying. Rock shall be excavated for the full specified width of the trench for a depth of 8 inches below the outer bottom of the pipe. Rock below the specified subgrade that is shattered and unfit for foundation in the Authority's opinion shall be removed and the area backfilled to the proper subgrade with Class B concrete or coarse aggregate subgrade material. Rock encountered at blank connections or stubs shall be excavated at least 10 feet from the blank connections in the direction of any proposed future extension, and the excavation shall conform to the requirements for the extension.

5.9 Explosives & Blasting

Blasting procedures shall conform to Pennsylvania Department of Labor and Industry regulations, AWWA C600, Section 6.12, and NFPA 495, and any local requirements. Rock within 5 feet of any existing water or gas main, sewer, electrical conduit, or other utility or structure shall be removed by means other than blasting. EAWA reserves the right to designate any other specific limits of the work in which rock shall be removed by means other than blasting. A licensed blaster is required and a seismographic monitoring plan shall be implemented. Where lines pass in vicinity of existing construction, the contractor shall be required to perform a pre-blast survey of the existing structures to established baseline conditions. This should be done by a licensed engineer specializing in this work.

5.10 Width & Depth of Pipe Trenches

The width and depth of pipe trenches shall conform to the dimensions shown on the attached standard detail drawing. Trench sides shall be vertical, and dimensions shall apply to the inside faces of any required sheeting. The trench depth shall include a 4 ft. depth of cover.

5.11 Preparation of Pipe Trenches

Pipe trenches shall be uniformly graded to planned subgrade. If subgrade conditions are satisfactory, as determined by EAWA, aggregate bedding material shall be furnished and placed as described below. If subgrade conditions are not suitable, Contractor shall excavate the unsuitable material and backfill as per standard detail.

5.12 Bedding Material

stone bedding shall consist of a 4 - 6 inch encasement of 1B (AASHTO #8) stone to be placed in two lifts. The first lift shall be filled to $\frac{1}{2}$ of the pipe barrel and chalked or vibrated underneath the pipe. The second lift is to be placed at a height of six (6) inches above the pipe and leveled out.

5.13 Sheeting, Shoring, Bracing

Sheeting, shoring, and bracing shall conform to Pennsylvania Department of Labor and Industry Regulations, OSHA Regulations, and AWWA C600, Section 6.13.

5.14 Backfilling Trenches

Trenches shall be constructed and backfilled in accordance with EAWA Standards. Trench backfill shall conform to Penn DOT 459 Regulations, Penn DOT Highway Occupancy Permit Regulations, and AWWA C600, except as specified herein and on the standard trench details. Backfill material shall be carefully placed in trenches according to specified layer thickness, and each layer shall be thoroughly compacted. The amount of compaction equipment and compaction effort is subject to EAWA approval.

a. Common Backfill:

Select backfill material shall consist of clean, dry earth and shall not contain stones larger than 1 inch. Excavated material may be used if approved by EAWA.

b. Trenches Located on State Highways:

All trench excavation and backfill on State Highways shall conform to Penn DOT requirements. The Applicant shall pay all costs of Penn DOT inspections and permits.

c. Trenches Located in the EAWA Service Area Streets (non-state highways):

Trenches located along EAWA service area streets shall be refilled with Penn Dot 2A Aggregate in 12- 18 inch mechanically compacted layers from a point six (6) inches above the top of pipe.

d. Unpaved Areas Not Subject To Traffic:

Trenches in unpaved areas, not subject to traffic, shall be refilled from a point 6 inch above the top of pipe to the existing grade by 12- 18 inch mechanically compacted layers, with common backfill. In areas requiring seeding, the backfill shall be terminated 6 inches below the existing grade, and refilled with 6 inches of approved topsoil.

5.15 Existing Underground Utilities / Obstructions

Contractor shall be responsible for PA One Call notification. The Contractor shall be responsible for all damage to existing underground utilities due to operations. The Contractor shall determine the correct location of utilities by means of exploratory test pits and information obtained from utility owners; and shall be responsible for all utilities and other obstructions, whether or not they are shown on the drawings or are located incorrectly.

Contractor shall uncover and verify the location of utilities and other underground obstructions far enough in advance of the pipe laying to permit changes in pipe alignment or grade to bypass the obstructions without removing pipeline. If necessary, the Contractor shall be responsible for removing and reinstalling the pipe at his own expense to avoid utilities. Contractor shall support utility poles located at or near the trench line limits, and shall contact utilities for pole supports when necessary. If the utility poles are damaged, the Contractor shall be responsible for repairs.

5.16 Change of Trench Location / Depth

EAWA reserves the right to require changes in the trench location or depth. If field conditions require the lowering of the pipe to a depth greater than that specified, the Contractor shall obtain approval from the Authority to install the pipe at the lower depth. If the Contractor installs the pipe at the lower depth without such approval, and the Authority determines that a different pipe class is required at the lower depth, the Contractor shall excavate and remove the pipe of the lower class and shall install the pipe class required by the Authority at his or her own expense.

5.17 Installation of Pipe

Installation and handling of DICL pipe shall conform to AWWA Standard C600, except where otherwise specified herein. The Contractor shall be responsible for all

material, and shall replace at his own expense all such materials found defective in manufacture or damaged in handling, as determined by EAWA which may include:

- a. Damage to interior or exterior paint seal coats;
- b. Damage to interior cement-mortar lining;
- c. Insufficient cement-mortar lining thickness;
- d. Poor quality interior paint seal coat causing a partial obstruction in the pipe round;
- e. Pipe out of round;
- f. Damaged pipe barrel area causing a reduction in effective pipe thickness;
- g. Any material that is dropped during handling, regardless of its apparent condition.

Pipe shall be handled so that the coating and lining is not damaged. Valves and hydrants shall be stored and kept dry before installation.

5.18 Alignment & Grade

Where the proposed pipeline route is on a curve, the Contractor may deflect the pipe at the joints to published manufacturer tolerances. Where underground conditions require a change of alignment or grade, such change shall be made only with the written consent of EAWA. When a change in grade is indicated which will result in the pipe having more cover than originally anticipated, the class of pipe installed at the location shall withstand the new loadings. Except at predestinated points, no high points shall be established where air can accumulate. If field conditions necessitate a change in the pipe profile and, in the opinion of EAWA, the change requires the installation of a fire hydrant; the Contractor shall install the same at no cost to the Authority.

5.19 Cleaning Pipe & Fittings

All lumps, blisters, and excess coating shall be removed from the end of each piece of pipe and fitting. The outside of the spigot the inside of the bell, and the gasket shall be thoroughly wiped clean and dry before the pipe is installed.

5.20 Laying Pipe

Following trench excavation, pipe laying shall proceed upgrade with pipe laid carefully, hubs upgrade, spigot ends fully centered into adjacent hubs, and true lines and grades given. Each section of pipe shall rest upon three, 4 inch concrete bricks spaced equally under pipe. Pipe shall be firmly held in position so that the invert forms a continuous grade with the invert of the pipe previously placed. The pipe bedding shall then proceed as described in Section 5.12.

Under no conditions shall pipe be laid in water, on subgrade containing frost, and/or when trench conditions are unsuitable for such work. In all cases, water shall be kept

out of the trench until concrete cradles, supports, encasement, or saddles, where used, and materials in the joints have hardened.

Any pipe that has its grade or joint disturbed after laying shall be taken up and relaid. Any section of pipe already laid and found to be defective shall be taken up and replaced with new pipe without expenses to EAWA. Walking or working on top of the completed pipeline, except as may be necessary in backfilling or tamping, shall not be permitted until the trench has been backfilled to a height of at least 3 feet over the top of the pipeline. At times when pipe laying is not in progress, the open ends of the pipe shall be closed by watertight plug. Joints shall be made according to supplier's specifications, and as per below instructions:

- a. Push-on Type Joints - Cleaning and assembly of push-on joints shall conform to AWWA C600, Section 9c.3. The inside of the bell and the outside of the spigot end shall be thoroughly cleaned to remove oil, grit, excess coating, and other foreign matter. These parts shall be kept clean throughout assembly at the joint. The circular gasket shall be flexed inward and inserted in the recess of the bell socket. Care shall be taken to insure that the gasket is properly seated. A minimum amount of lubricant shall be evenly applied to the spigot end with a brush. Gasket lubricant shall be as supplied by the manufacturer.

Proper positioning of the gasket shall be checked with a "feeler gauge" after each joint is made. The edges of field cut pipe shall be touched up with a file or grinder so as to remove rough edges and facilitate assembly.

- b. Mechanical Joints - The cleaning, assembly, and bolting of the mechanical joint shall conform to AWWA C600, Sections 9b.3 and 9b.4.
- c. Flanged Joints - Shall not be used for buried service. Larger diameter pipe, in pits / vaults, shall have the flanges wiped clean with a solvent-soaked rag prior to installation. The gasket shall also be wiped clean. Flanges shall be properly aligned and checked with a spirit level horizontally along the pipe and vertically across the flange faces. With flanges secured in position, half the bolts shall be inserted at the bottom of the flange, the gasket inserted between the flanges, and the remaining bolts inserted. The threads of the bolts shall be given a light coating of thread lubricant, and the nuts shall be installed on the bolts and turned up by hand. The nuts shall be tightened with a wrench by the crossover method to load the bolts evenly until the joints are tight.
- d. Mechanically Coupled Joints - Shall be installed in strict accordance with the manufacturer's instructions so as to insure permanently tight joints under all reasonable conditions of expansion, contraction, shifting, and settlement. The required torque ranges for the joint harness shall be as specified by the pipe manufacturer.

5.21 Setting Valves & Valve Boxes

All valves shall be provided with a valve box as detailed on the Drawings. Unless otherwise directed by EAWA, all valves shall be set with their stems perpendicular to the finished road surface. The tops of the valve box shall be set neatly to the grade of the surface of the existing ground. The valve box shall not transfer shock or stress to the valve and shall be centered and plumb over the wrench nut of the valve. All valves shall be set on a solid concrete block according to valve size.

5.22 Connections to Existing Water Lines

Prior to proceeding with installation, Contractor shall dig test pits to determine the exact location, elevation, and type of existing pipe and its outside diameter. Contractor is reminded that old water main pipe may vary in roundness and outside diameter, and consider this factor in ordering materials for the connection. Pits shall be protected and backfilled.

Each connection to the existing water line shall be made under pressure with a tapping sleeve and valve. If this is not possible, then the following conditions must be met. Once the existing main is cut, work shall be continuous until water service is restored. The Contractor shall take special precautions so as not to disturb the functional operation of the existing water main; except on a pre-planned scheduled basis, the time and date of which will be established in advance with the Authority Engineer. The Contractor shall at no time operate water valves in the existing water system without the presence of a duly qualified representative of EAWA. Contractor shall be responsible for working with EAWA to insure that customers, which may be affected, are given adequate public notice of the pending interruption of service.

If the condition of the connection is regulated by geometry, as determined by data obtained from the excavation of the test pits, the Contractor shall order any necessary additional materials. Restrained joints and tie rods and clamps shall be used to the maximum extent possible, in lieu of concrete thrust blocks. If it is necessary to use concrete thrust blocks, the high early strength cement-concrete shall be used.

5.23 Road Crossings

Where service lines cross highways or roads, a 1- ¼ inch (for ¾ inch service pipe) black steel casing pipe shall be installed across the road by boring, jacking, auguring, or drilling, and the service line shall be inserted in the casing pipe. If underground conditions do not permit boring, pushing, or jacking, the Contractor shall obtain EAWA approval before proceeding with an alternate method of installation. Penn DOT normally requires that water mains crossing state highways be installed in a casing pipe which shall be bored, jacked or augured under the highway. Service piping, inside black steel casing, shall be HDPE in accordance with Section 3.3.

5.24 Pavement Restoration

Elizabethtown Borough

Temporary Paving - At the end of each working day, the trench shall be temporarily paved with no less than a three (3) inch thick, tamped layer of cold patch material. The Contractor will be responsible for maintaining this temporary paving until such time that permanent paving-restoration occurs.

Permanent Paving - Shall not occur until the entire water line project is completely in place. The cold patch material shall be removed and the trench edges shall be saw cut back a minimum of 12 inches on both sides. The Contractor shall then match the types and thicknesses of existing pavement materials. However, under no circumstances shall there be anything less than 4 inches of BCBC and one and one half (1, ½) inch of wearing course.

Prior to placing any asphalt material in the trench, the sides of the existing asphalt shall be primed with AC-20. Upon completion of final compaction of the wearing course, the top edges will be sealed with AC-20. This paving specification applies to streets, alleys, parking lots, driveways and any other paved surface.

Mount Joy Township - Temporary Paving - same as above.

Permanent paving profile, for local roads, shall consist of: (a) 8" Subbase No. 2A stone; (b) 4" Superpave asphalt mixture, HMA base course, PG 64-22, 0.3 to < 3.0 M ESALS, 25 mm mix; (c) 1.5" Superpave asphalt mixture design, HMA wearing course, RPS, PG 64-22, 0.3 to < 3.0 M ESALS, 9.5 mm mix, SRL-H. Refer to MJT Ordinances for specifications relating to cross-section crown grade, and designs for Collector or Arterial type roads, as well as curb and sidewalk work. Work shall conform to Penn DOT form 408.

Finished joints of all openings shall receive a bituminous seal coat of RC-800 cutback asphalt, or approved equivalent, extending at least twelve (12) inches over the paving junction. A dusting of sand shall be applied to the seal coat as required to prevent tracking of the asphalt by vehicles.

West Donegal Township - Temporary Paving - same as above.

Permanent Paving - The existing surface shall be square vertical cut edges, and shall be a minimum of six (6) inches larger than the excavation opening on all sides. The existing surface, if bituminous, shall be tack coated to provide adherence of the new material.

Existing surface courses shall be replaced in kind, equal to the existing depth, except

that no surface course shall be less than three (3) inches in depth, consisting of a minimum of one and one-half (1 ½) inches of ID-2 Binder course and one and one half (1 ½) inch of ID-2 Wearing course, conforming to Penn DOT form 408.

- a. Paving in streets intended to serve as rural roads and in residential developments shall be constructed as follows:
 1. Subbase course: 6 inches of 2A subbase;
 2. Base course: 5 inches of bituminous concrete base course or superpave equivalent;
 3. Binder course: 2 ½ inches of bituminous concrete ID-2 binder material or superpave equivalent;
 4. Wearing course: 1 ½ inches of bituminous concrete ID-2 wearing material or superpave equivalent.

- b. Paving in streets intended to serve as collector or arterial roads or as part of industrial or commercial developments shall be constructed as follows:
 1. Subbase course: 6 inches of 2A subbase;
 2. Base course: 6 inches of bituminous concrete base course or superpave equivalent;
 3. Binder course: 3 inches of bituminous concrete ID-2 binder material or superpave equivalent;
 4. Wearing course: 1 ½ inches of bituminous concrete ID-2 wearing material or superpave equivalent.

Finished joints of all openings shall receive a bituminous seal coat of RC-800 cutback asphalt, or approved equivalent, extending at least twelve (12) inches over the paving junction. A dusting of sand shall be applied to the seal coat as required to prevent tracking of the asphalt by vehicles.

5.25 Length of Open Trench

EAWA reserves the right to limit the amount of trench opened in advance of pipe laying to not more than 100feet and the amount of pipe laid in advance of backfilling not more than 50 feet. At the close of work at night or at the discontinuance of work, no open trenches are allowed.

5.26 Cleanup

As trenches are backfilled, the Contractor shall immediately remove and dispose of all surplus material. If Contractor fails to keep work site, roads, sidewalks, and other areas free of surplus material, he shall be so notified. If the condition remains, Contractor shall be billed for work to clean all area.

SECTION VI – INSPECTIONS & TESTING

6.0 General

Inspections and testing shall be done according to a pre-arranged tentative schedule, provided to EAWA at the pre-construction meeting, which shall occur a minimum of 2 weeks prior to any excavation, construction, or installation. EAWA shall have the right to inspect any construction, equipment, facilities, connections, or related works, made to its system, for the following:

- a. Installation of new, repaired, or replaced mains;
- b. Extensions of its distribution system, or mains;
- c. Excavation, trenching, bedding;
- d. Testing of mains for pressure leaks, and disinfection;
- e. Backfilling, pavement / site restoration;
- f. Service lateral connections (including: from corporation stop to curb stop, on the water service piping from curb stop valve to meter valve before backfilling, meter piping and valve installation, prior to installation of the meter, installation of meter);
- g. During other critical phases of work on its system, as deemed appropriate by EAWA.

Inspections will be reviewed and documented in accordance with Appendix 1- Water Connection Inspection Form. Changes to the tentative inspection and testing dates will require at least 48 hours prior notice to EAWA or its Engineer. Should the inspected work prove unsatisfactory, the cost of removing and replacing, renewing and making good the unsatisfactory work shall be borne by the Applicant. No water service facility shall be placed in service until it has been successfully tested in the presence of an authorized Authority representative.

6.1 Hydrostatic & Leakage Test

The section of water main being pressure tested shall be filled with water for a minimum of 48 hours before the main and valves are tested. The Contractor shall insure that air is expelled from the main as per AWWA C600 standards. Any taps necessary to release air or water from the main during testing shall be made at the Contractor's expense, unless retained by EAWA for other use. The duration of the pressure test shall be at least one hour. Each section of water main shall be tested at 150 PSI, or as approved by EAWA, at the highest hydrant.

The proposed test pressure shall be approved by the Authority prior to testing, and the Contractor shall not employ a test pressure which exceeds the allowable pressure of any installed pipe, valve, or appurtenance. In order to successfully pass the pressure test the line or section of line being tested cannot lose any pressure during the one hour test.

6.2 Disinfection

Before being placed into service, all pipe installed shall be disinfected by chlorination in accordance with AWWA C601, except as otherwise specified herein. Prior to disinfection, the sections of pipe being disinfected shall be flushed thoroughly. The Contractor shall use calcium hypochlorite solution for disinfection in accordance with AWWA C651. A chlorine water solution of 1% available chlorine shall be prepared, using granular calcium hypochlorite, and this solution shall then be injected or pumped into the pipeline. A chlorine water solution of 1% available chlorine may be prepared by mixing approximately 1 pound of calcium hypochlorite with 8.5 gallons of water.

The hypochlorite solution shall be applied to the main with an electrical chemical feed pump, designed for feeding chlorine solutions. For smaller applications, the solution may be prepared in a barrel, and then pumped into the main with a hand pump. Below table provides the amount of calcium hypochlorite and the quantity of 1% hypochlorite solution required to produce a 50 p.p.m. chlorine concentration in 100 feet of Pipe:

Pipe Size Solution Inches	Contents in 100' Section			Amt of Calcium Hypochlorite		Chlorine
	Ft ³	Lbs	Gallons	Ounces	Lbs	Gallons
6	19.6	1225	147	1.5	0.091	0.73
8	34.9	2180	261	2.5	0.159	1.3
10	54.55	3405	408	4	0.252	2.06
12	78.55	4905	588	5 5/8	0.35	2.88
16	139.6	8725	1044	10	0.621	5.22

In lieu of solution, dry powder may be used to produce the identical concentration noted above.

6.3 Point of Application

The chlorinating agent shall be applied at the high end of the pipe section, and through a corporation stop inserted in the top of the new pipe. If the water for the preparation of the chlorine solution is supplied from a tap on the existing pipeline, there shall be a physical break between the injector supply and the injector pump.

6.4 Rate of Application

The solution shall be pumped slowly into the new pipeline, and shall not cease until

the entire main is filled with the chlorine solution. If required by EAWA / its Engineer, the chlorine residual shall be measured at several points along the section of main being tested to insure that the proper dosage and distribution of the chlorine solution is obtained. Great care shall be exercised in manipulating valves, so that the strong chlorine solution in the line being treated will not flow back into the adjoining water distribution system.

6.5 Retention Period & Chlorine Concentration

The chlorinated water shall be retained in the main for at least 48 hours, during which time all valves and hydrants in the section treated shall be operated, in order to disinfect the appurtenances. At the end of this 48 hour period, the treated water shall contain no less than 25 p.p.m. chlorine throughout the length of the main. Should the initial procedure fail to result in the conditions specified, the chlorination procedure shall be repeated until such results are obtained, at the Contractor's expense.

6.6 Point of Discharge / Disposal

The Contractor shall discharge the disinfecting solution from the mains through available outlets, through taps in the main. The Contractor shall exercise all due precautions in discharging the chlorine bearing water; since it is extremely toxic and, if allowed to flow into streams, can readily destroy aquatic life. If any damage to property or fish life occurs due to the disposal of the disinfecting solution, the cost of the damage shall be paid by the Contractor. If the possibility of damage to aquatic life is such, in the opinion of the Engineer, that special precautions are required, the Contractor shall de-chlorinate the disinfecting solution before it goes to waste. The chlorine solution may be neutralized by applying sodium thiosulfate in the ratio of 2 parts thiosulfate to 1 part chlorine at the point of discharge. Contractor shall comply with County Conservation District Requirements.

6.7 Final Flushing

Following chlorination, the water shall be thoroughly flushed from the line at its extremities until the replacement water is proven to be comparable to the quality of water in the existing distribution system. Water for flushing will be provided by the Authority, but at no time shall valves on the water distribution system be operated without the presence of a duly qualified EAWA representative.

6.8 Water for Testing

Water will be furnished by the Authority for one hydrostatic test and disinfection procedure. If pipelines must be retested and disinfected, the cost for additional water will be borne by the Contractor at a cost rate determined by the Authority.

After final flushing is completed and before the water main is put into service, the Contractor shall have the replacement water tested for bacteriological quality by a PA DEP certified laboratory. A certified copy shall be sent to EAWA.

6.9 Alternate Disinfection of Water Main Connection

As it may not be possible to disinfect the pipe, valves, and fittings installed at certain connections in the manner specified above, the Contractor may use the following procedure after obtaining written EAWA approval. Every precaution shall be observed during the installation of the connection to prevent foreign material and trench water from entering the pipe, fittings, and valves during their installation. The disinfection of the interior of all pipe, fittings, and valves shall be swabbed with a 5% Hypochlorite solution, which can be obtained by mixing approximately 3 lbs. of granulated calcium hypochlorite with 5 gallons of water.

After the pipe, fittings, and valves have been swabbed, they shall be thoroughly flushed with water. The Contractor is reminded that the de-chlorinated water must be disposed of in a manner that does not harm fish life, or vegetation, and is in compliance with Federal, State and County Conservation District regulations.

**APPENDIX 1 - WATER MAIN CONNECTION INSPECTION FORM
(AKA DEVELOPMENT / SUBDIVISION PLAN INSPECTION)**

- Confirm if developer / contractor has scheduled a Pre-construction – Scheduling meeting with EAWA staff. Ideally, this should occur a minimum of 2-weeks prior to any construction – installation of water mains;
- Schedule should generally outline sequence and tentative dates for installation, testing, and disinfection. Authority may waive schedule, at its discretion, for minor projects;
- Attach photographs on separate sheet, and document.

Date of this Inspection:		
Name of EAWA Inspecting Engineer of Staff:		
Initial Inspection:	Interim Insp.:	Final / As-built:
Date of Site Excavation:		
Date of Installation:		
Temp. / Weather / Conditions:		

Plan / Project:

Project Name:	
Location:	
Name of Developer:	
Cell #:	
Name of Contractor / Site Foreman:	
Cell #:	

Ensure that Contractor / Construction Manager has copy of latest, revised Development / Water Utility Plans:

Ensure Plan is dated, signed & sealed by Developer's PE / PLS:

Describe all deviations from approved plan / problems observed. If NONE – indicate “OK”; If work not observed – write: “Not Inspected / Observed”.

	Inspection Notes:	Date of Completion / Date of Required Correction:
Road access restrictions / Signing / Barricading:		
Connection to existing Water main:		
Construction site staking:		
Ensure trench excavation (depth, location, etc.) is per approved plan and appropriately maintained:		
Existing utilities must be adequately protected and the waterline must be continuously supported:		
Note any water main deviations from plans (depth, size, type):		
Ensure that the pipe is properly assembled prior to bedding and backfilling of the trench:		
Pipe markings as per AWWA C-104, C-110, C-111, C150, C-151, C-153, C-400, ASTM D-1869:		
Note water main elevation profile / separation from sewer and stormwater pipes:		
Note bedding profile and compaction - ensure that compaction of the bedding material is satisfactory prior to backfilling:		
Note separation to other utilities:		
Verify if joint restraint been provided per EAWA specifications:		
Valve / Corporation / Curb stops:		
Pressure / Leakage Testing - DICL – test for leakage between valves. After pipeline has been filled with water for 48 hours and all air removed, a PT of 150 psi will be applied for 1 hour w/o loss of pressure:		

Copper and HDPE pipe tubing –
 Test piping 2-inch and less in
 diameter after installation at 150
 psi. Pipe shall hold pressure for 1
 hour w/o pressure loss:

Observe and document all pressure
 leakage (segment, duration,
 pressure). Gauges shall have
 recent calibration tests:

Disinfection - ensure that the
 contractor uses the proper
 equipment and techniques to
 disinfect all of the new lines. Obtain
 bacteriological results:

Curb Stops:

Service Laterals (copper or HDPE):

Fire Hydrants / Valves - ensure that
 valve, assembly, and all fittings are
 installed as required by plans and
 specifications. Verify finished grade,
 and that valve operates correctly:

Meter / meter pit (note size, type):

Pavement / site restoration (note
 any settlement observed above
 backfilled trench):

Review Inspector's certification:

I, _____, certify that I inspected the actual installation of
 proposed improvements and installation, in accordance to the Developer's
 prepared Plans / As-built Plan / Individual Connection Permit, and that all intended
 improvements have been correctly completed and installed.

Print name here:

Date:

APPENDIX 2 – APPROXIMATE WATER USAGE GUIDELINE

Facility	Unit	Flow, gallons/unit/day		Flow, liters/unit/day			
		Range	Typical	Range	Typical	(2) Avg. Use in L/day/m2	(2) Peak Use in L/day/m2
Airport	Passenger	2 to 4	3	8 to 15	11		
	Person	40-80	50	150-300	190		
Apartment house	DU					821	1,640
	Vehicle served	8 to 15	12	30-57	45		
Automobile service station	Employees	9 to 15	13	34-57	49		
	Customer	2 to 4	3	8 to 15	11		
Bar	Employees	10 to 16	13	38-61	49		
	Chair					207	1470
Beauty Shop	Chair					1020	4050
Boarding house / B&B	Person	25-60	40	95-230	150		
Bowling	Alley / Lane		75			503	503
Car wash	m2					194.7	1,280
	Vehicle served		28				
Church	Seat		2			0.5	17.8
Church w/ kitchen / banquet	Seat		5				
College, Residential	Student					401	946
Department store	Toilet room	400-600	500	1,500-2,300	1,900		
	Employee	8 to 15	10	30-57	38		
Golf - Swim Club	Guest					117	84
	Guest	40-60	50	150-230	190		
Hotel	Room		60				
	Employee	8 to 13	10	30-49	38		
Motel	m2					10.4	17.6
	m2					9.1	63.1
Hospital	Bed	300 - 346				1,310	3,450
Nursing Home	Bed	133 - 150				503	1,600
Industrial building (sanitary waste only)	Employee	7 to 16	13	26-61	49		
Industrial (with showers)	Employee		35				
Laundry (self-service)	Per Machine	450-650	550	1,700-2,500	2,100		
	m2					88.4	265
Office	Per Wash	45-55	50	170-210	190		
	Employee	7 to 16	13	26-61	49		
Medical Office	ff2		0.15				
	m2					3.8	21.2
Public lavatory	User	3 to 6	5	11 to 23	19		
Restaurant (with toilet)	Meal	2 to 4	3	8 to 15	11		
	Customer	8 to 10	9	30-38	34		
Conventional	Seat		35				
Fast food / Short order	Customer	3 to 8	6	11 to 30	23		
Service Station	m2					10.2	1,280
Service Station w/o car wash	Pump Island		500				
School, Elemen.	Student		15			20.4	186
School, High	Student		20			25.1	458
Retail	Employee		20				
	ff2		0.1				
Shopping center	m2					4.3	11
	Employee	7 to 13	10	26-49	38		
Theater / Movie	Parking Space	1 to 3	2	4 to 11	8		
	Seat	2 to 4	3	8 to 15	11	12.6	12.6

Data incorporates the effect of fixtures complying with the U.S. Energy Policy Act (EPACT) of 1994.
 Source: Crites and Tchobanoglous, 1998; EPA (Feb. 2002) Onsite Wastewater Treatment Systems Manual. Office of Water, Research and Development, EPA /625/R-00/008. (2) 2 - Mays, L., (2001) Water Resources Engineering. John Wiley & Sons. 1st Ed. Ohio Environmental Protection Agency, (April 2010), Guidelines for Design of Small Public Ground Water Systems, 4th Ed.

Exhibits / Illustrations – *SEE separate attachments.*

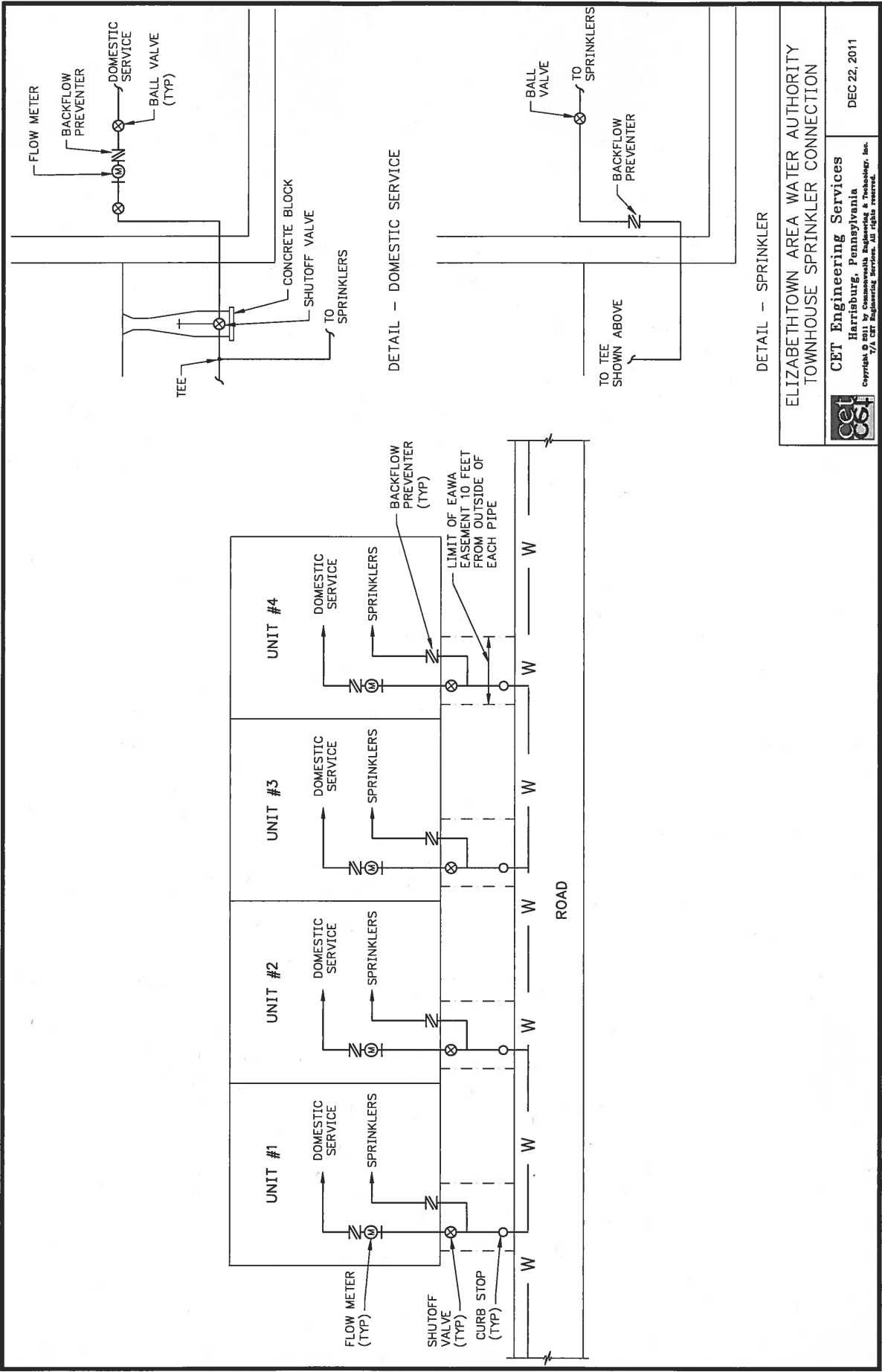

DETAIL - DOMESTIC SERVICE

DETAIL - SPRINKLER

ELIZABETHTOWN AREA WATER AUTHORITY
TOWNHOUSE SPRINKLER CONNECTION

CET Engineering Services
Harrisburg, Pennsylvania
Copyright © 2011 by Commonwealth Engineering & Technology, Inc.
7/4 CET Engineering Services. All rights reserved.

DEC 22, 2011

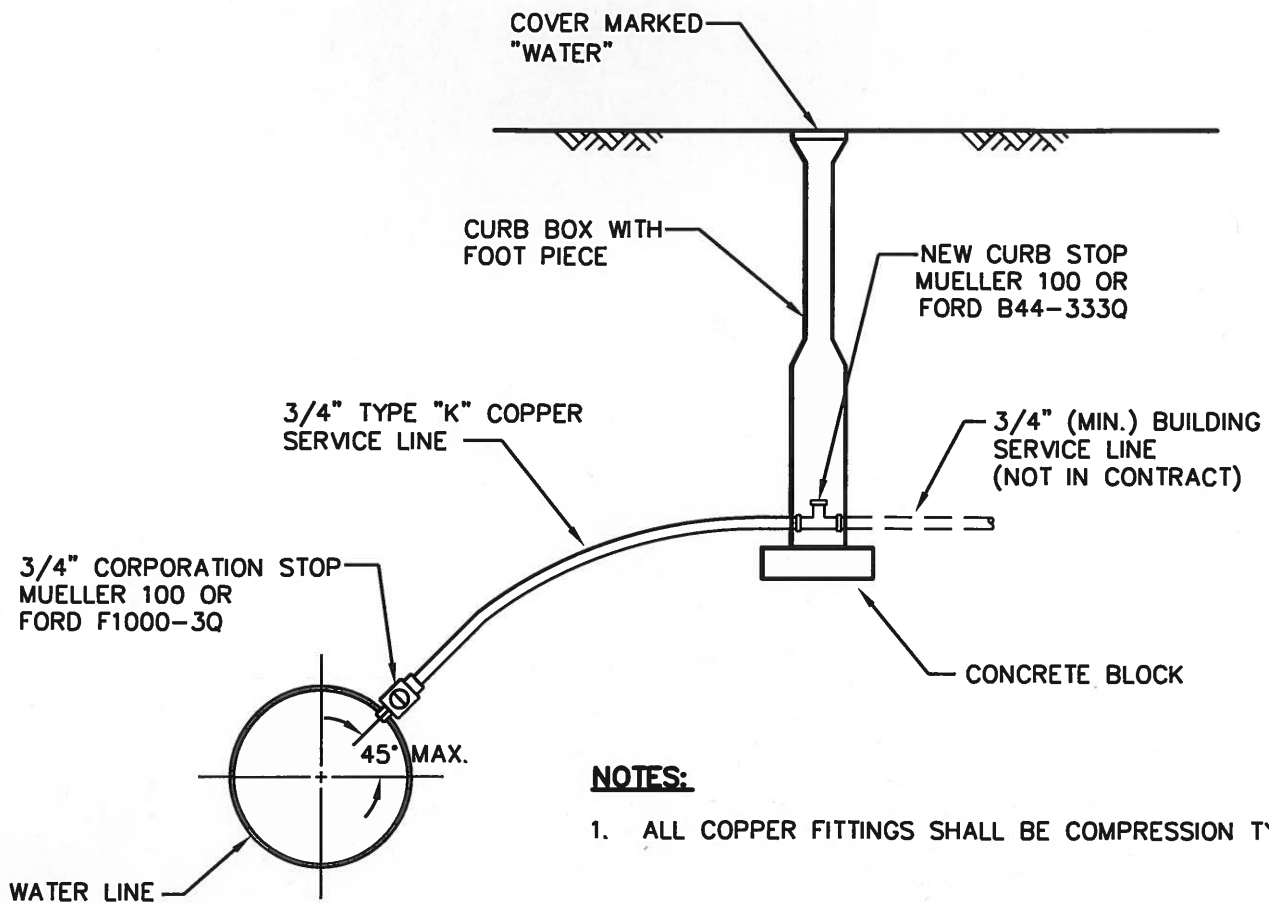

NOTES:

1. ALL COPPER FITTINGS SHALL BE COMPRESSION TYPE.

SERVICE CONNECTION DETAIL

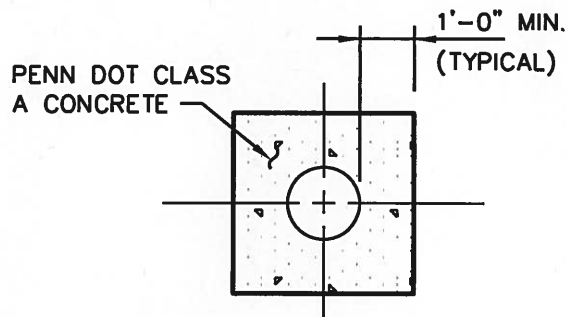

CONCRETE ENCASEMENT DETAIL

TITLE:	SERVICE CONNECTION AND CONCRETE ENCASEMENT DETAILS		DATE	REVISIONS
CET Engineering Services Harrisburg, Pennsylvania	Copyright © 2013 by Commonwealth Engineering & Technology, Inc. T/A CET Engineering Services. All rights reserved.		SCALE	DRAWING NO.
			NO SCALE	DET-03

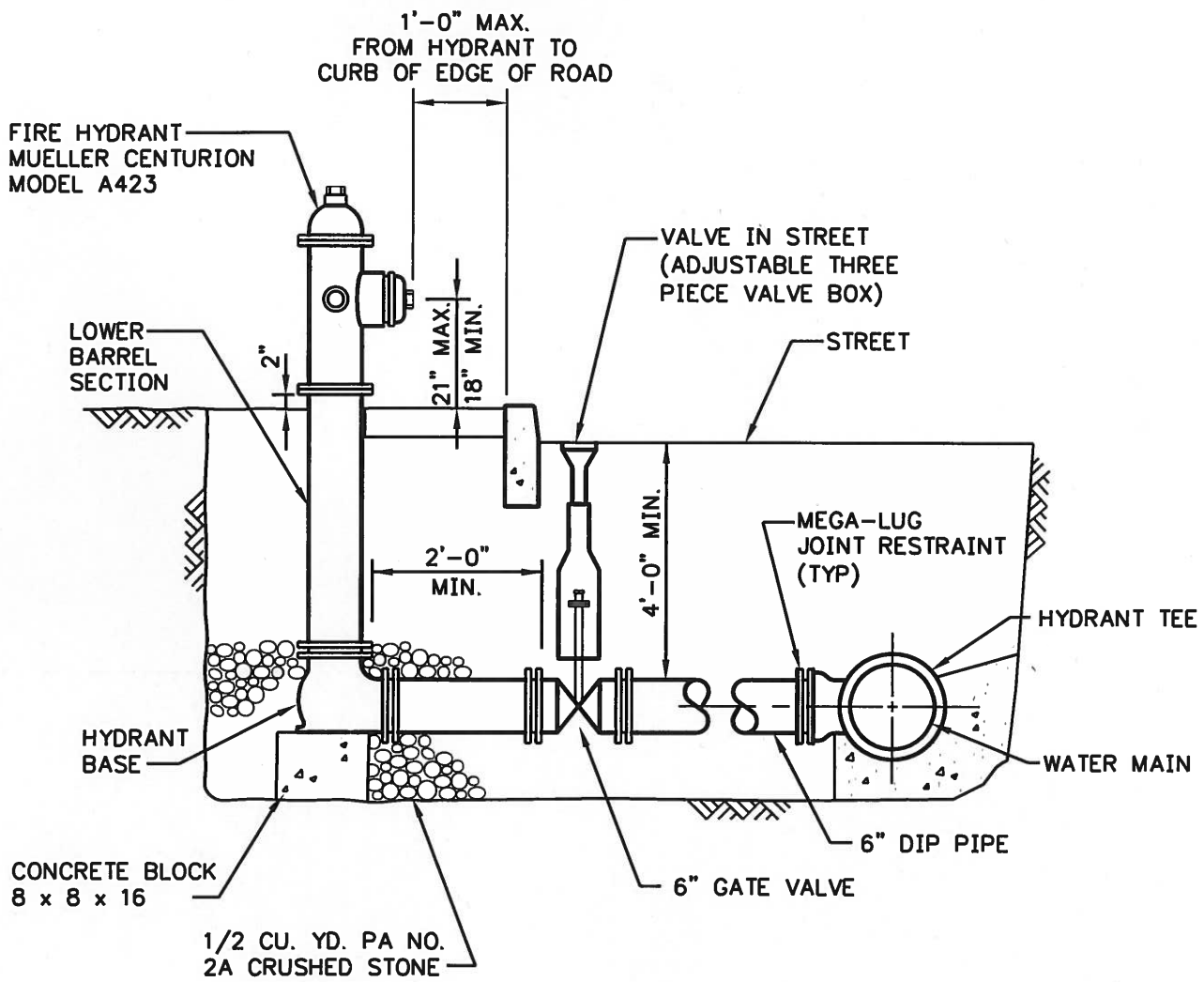

FIRE HYDRANT DETAIL

DATE	REVISIONS

CET Engineering Services
Harrisburg, Pennsylvania

Copyright © 2013 by Commonwealth Engineering & Technology, Inc. T/A CET Engineering Services. All rights reserved.

SCALE NO SCALE	FILE DET - 04
-------------------	------------------

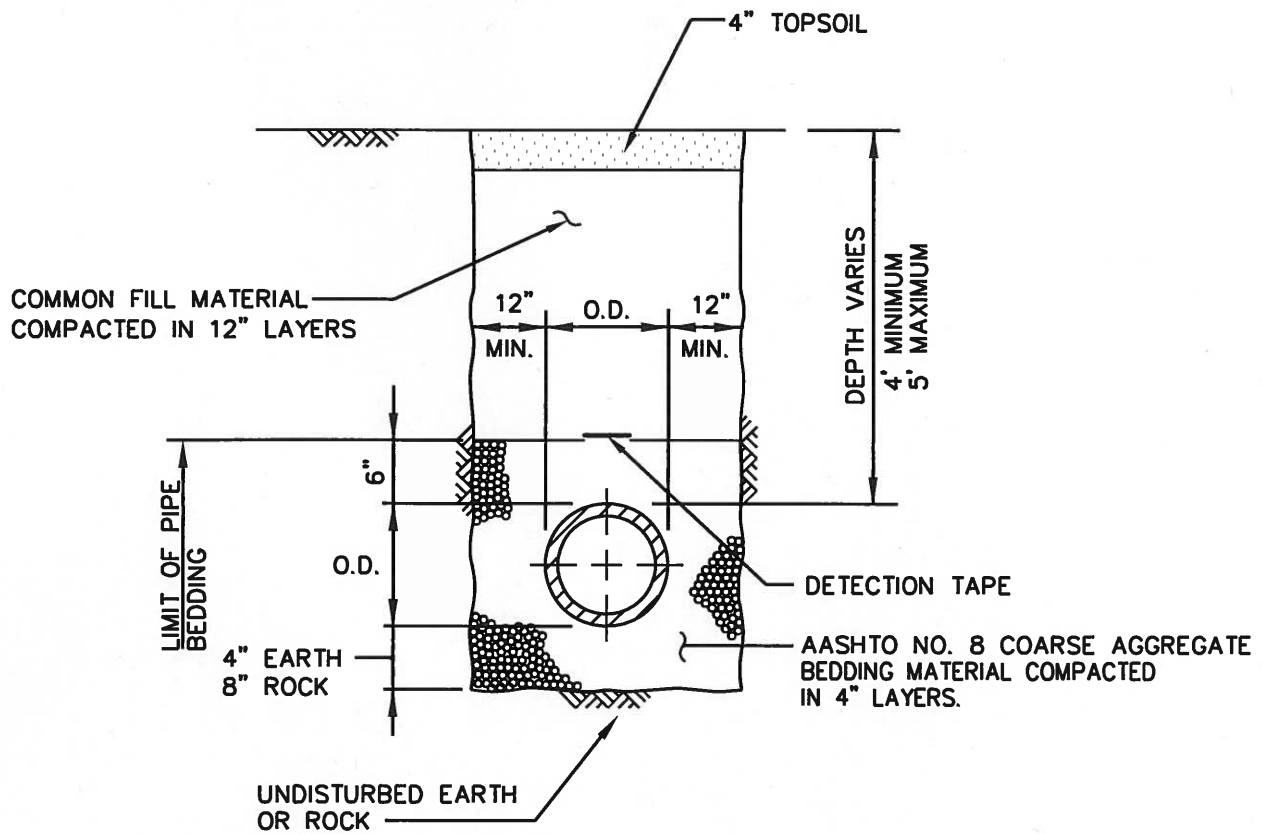

WATERLINE TRENCH DETAILS – UNPAVED AREAS

DATE

REVISIONS

CET Engineering Services

Harrisburg, Pennsylvania

Copyright © 2013 by Commonwealth Engineering & Technology, Inc. T/A CET Engineering Services. All rights reserved.

SCALE
NO SCALE

FILE
DET - 05

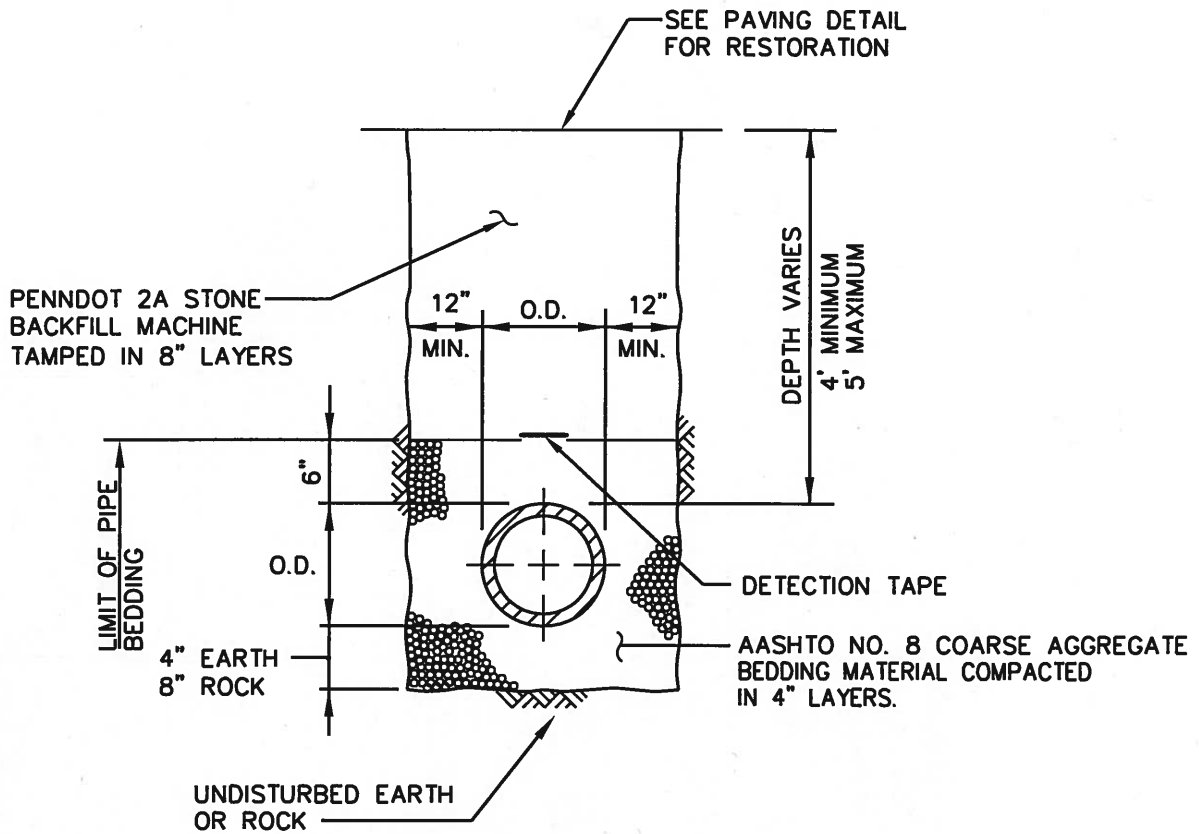

WATERLINE TRENCH DETAILS – PAVED AREAS

DATE	REVISIONS

CET Engineering Services
 Harrisburg, Pennsylvania

Copyright © 2013 by Commonwealth Engineering & Technology, Inc. T/A CET Engineering Services. All rights reserved.

SCALE NO SCALE	FILE DET - 05A
-------------------	-------------------

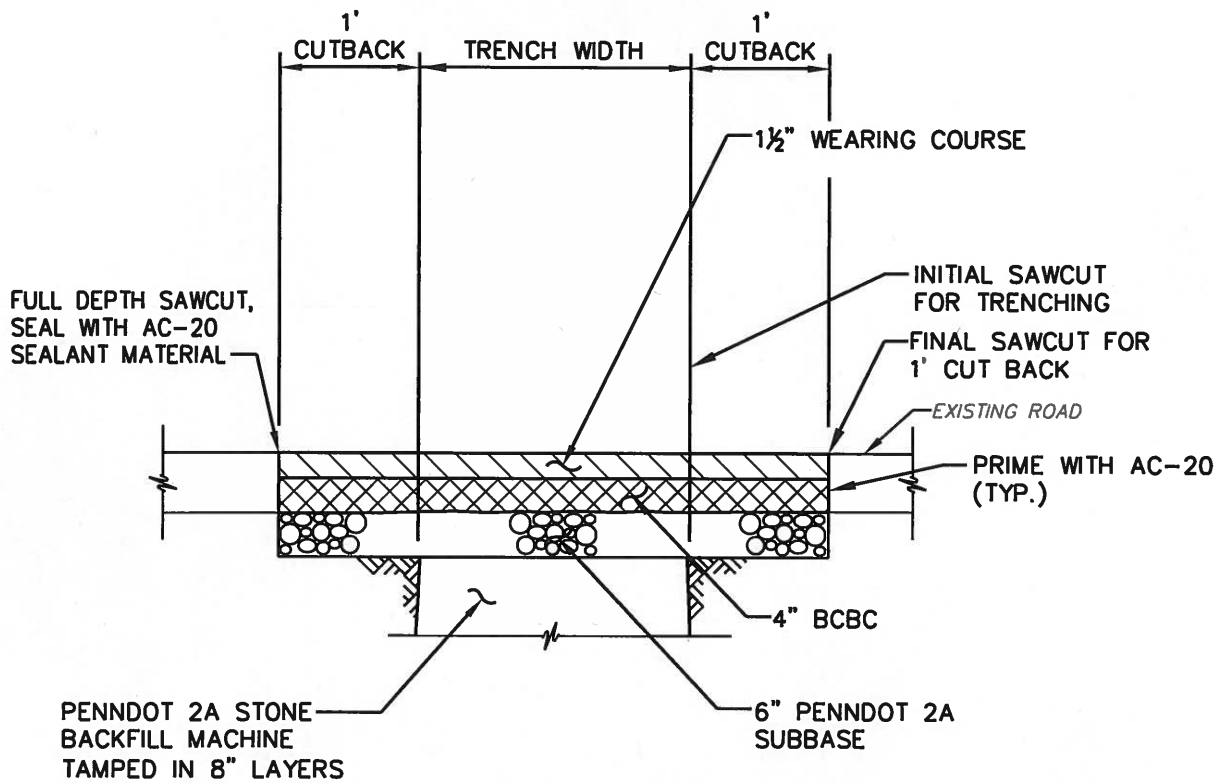

ELIZABETHTOWN BOROUGH PAVING RESTORATION

DATE	REVISIONS
SCALE NO SCALE	FILE DET - 058

CET Engineering Services

Harrisburg, Pennsylvania

Copyright © 2013 by Commonwealth Engineering & Technology, Inc. T/A CET Engineering Services. All rights reserved.

SUPERPAVE ASPHALT MIXTURE DESIGN,
HMA WEARING, PG64-22,
0.3 MILLION TO < 3 MILLION ESAL'S
12.5mm, 1½" DEPTH, SRL-L

SUPERPAVE ASPHALT MIXTURE DESIGN,
HMA BINDER COURSE, PG 64-22
0.3 MILLION TO < 3 MILLION ESAL'S
25MM MIX., 2½" DEPTH

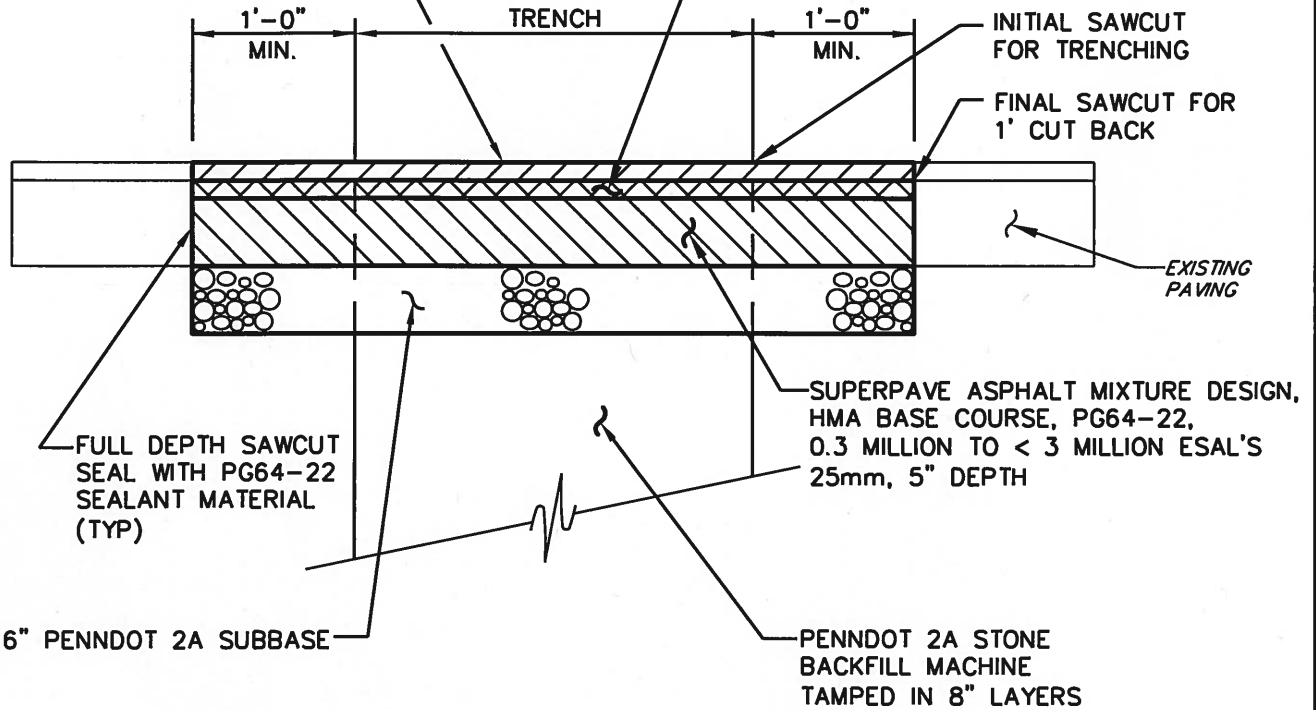

FOR RURAL ROADS & RESIDENTIAL DEVELOPMENTS

WEST DONEGAL TOWNSHIP PAVING RESTORATION

CET Engineering Services
Harrisburg, Pennsylvania

Copyright © 2013 by Commonwealth Engineering & Technology, Inc. T/A CET Engineering Services. All rights reserved.

DATE	REVISIONS
SCALE NO SCALE	FILE DET - 05D

SUPERPAVE ASPHALT MIXTURE DESIGN,
HMA WEARING, PG64-22,
0.3 MILLION TO < 3 MILLION ESAL'S
12.5mm, 1½" DEPTH, SRL-L

SUPERPAVE ASPHALT MIXTURE DESIGN,
HMA BINDER COURSE, PG 64-22
0.3 MILLION TO < 3 MILLION ESAL'S
25MM MIX., 3" DEPTH

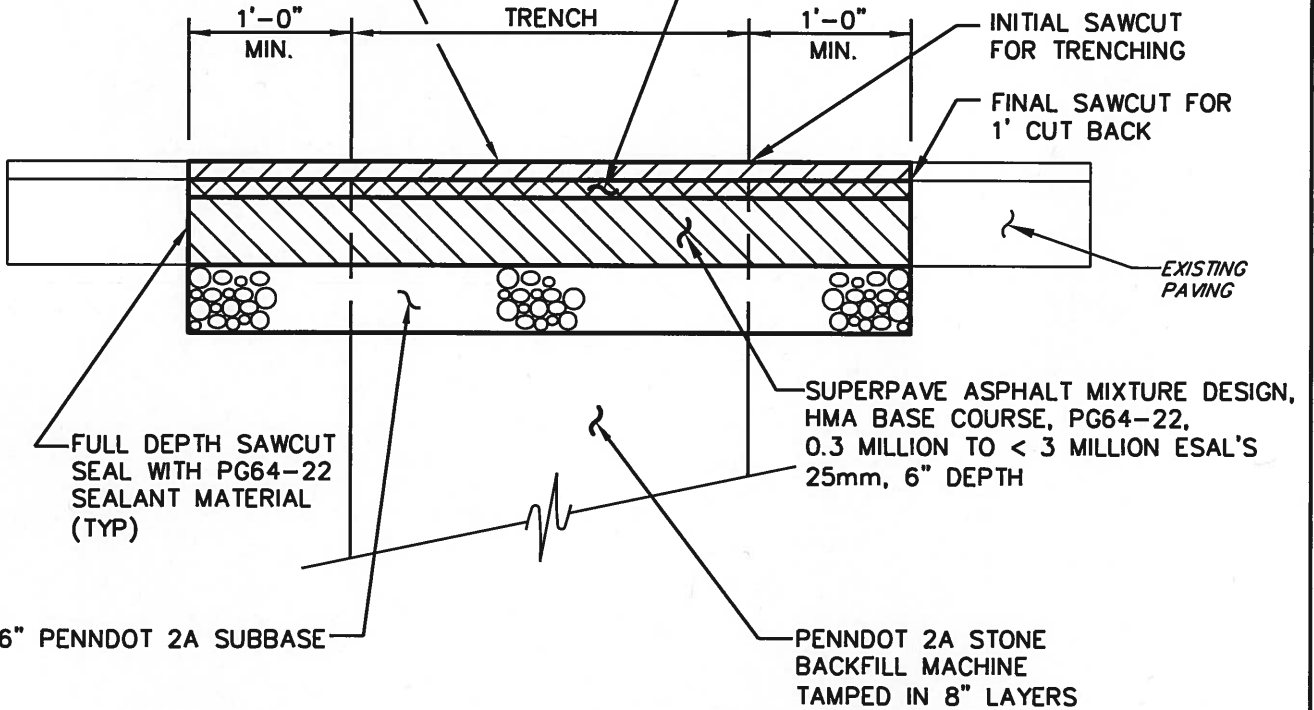

FOR INDUSTRIAL AND COMMERCIAL DEVELOPMENTS

WEST DONEGAL TOWNSHIP PAVING RESTORATION

CET Engineering Services

Harrisburg, Pennsylvania

Copyright © 2013 by Commonwealth Engineering & Technology, Inc. T/A CET Engineering Services. All rights reserved.

DATE	REVISIONS
SCALE NO SCALE	FILE DET - 05E

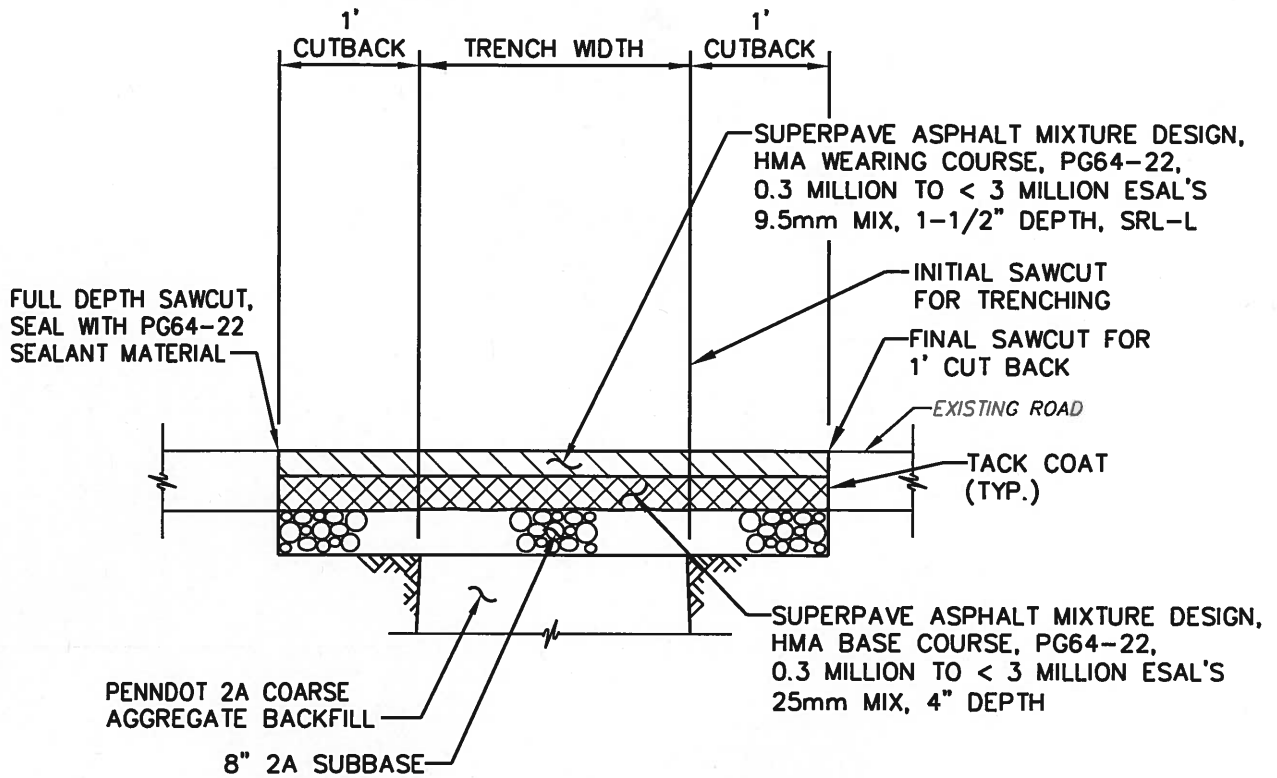

MOUNT JOY TOWNSHIP PAVING RESTORATION

CET Engineering Services

Harrisburg, Pennsylvania

Copyright © 2013 by Commonwealth Engineering & Technology, Inc. T/A CET Engineering Services. All rights reserved.

DATE	REVISIONS
SCALE NO SCALE	FILE DET - 05C